

Blancett®

Flow Meters



FloClean™ 3-A Sanitary Turbine Flow Meter

- Meets 3-A Sanitary Standard 28-03
- Accuracy of $\pm 1.0\%$ of reading
- Repeatability of $\pm 0.1\%$
- 0.6 to 400 GPM flow rates
- Materials comply to FDA requirements

1-800-235-1638 ■ www.blancett.com



Introduction

The FloClean Sanitary turbine flow meter was developed for use in the food, beverage and pharmaceutical industries. The 316L stainless steel construction provides a durable and cost efficient flow measurement system that offers excellent accuracy and repeatability.

The FloClean utilizes the most up-to-date polishing technology on all internal components and all materials comply with FDA requirements. FloClean meets the requirements of 3-A Sanitary Standard number 28-03 for use in clean-out-of-place (COP) and sanitize-out-of-place (SOP) applications.

The FloClean output signal is a sine-wave that is proportional to volumetric flow. With optional Blancett electronics, FloClean provides local flow rate and volume totalization and will interface with most displays, PLCs and computers.



FloClean 3-A (COP) Sanitary Meter with NEMA 6 pick-up (P.N. B16A-110A-1BA)

Operating Principle

Fluid entering the meter first passes through an inlet flow straightener that reduces its turbulent flow pattern. Fluid then passes through the turbine, causing the turbine to rotate at a speed proportional to fluid velocity. As each turbine blade passes through the magnetic field generated by the meter's magnetic pick-up, an AC voltage pulse is generated. These pulses provide an output frequency that is proportional to volumetric flow.

Specifications

Materials of Construction:

- Body and Internal Wetted Parts: 316L Stainless Steel
- Bearings: Standard - Nickel Bindery Tungsten Carbide
- Turbine: Nickel Plated CD4MCU Stainless Steel
- Shaft: Nickel Bindery Tungsten Carbide

Flow Accuracy: ±1.0% of reading

Repeatability: ±0.1%

Calibration: Water (NIST Traceable Calibration)

Pressure Rating: 1,000 psi (Rating based on Tri-clamp sanitary connection)

Turbine Temperature: -150 to +300 °F (-100 to +149 °C)

End Connections: Sanitary Clamp End

Mag Pick-up (option 0): NEMA 6; -150 to +300 °F (-100 to +149 °C)

Repair Kits

Factory calibrated replacement kits are available for field or factory service. FloClean models are designed to allow for quick, easy disassembly and replacement of the meter's internal components. The repair kit contains two retaining rings, two rotor supports, one rotor assembly, and a K-factor tag.

For further details, contact the factory or refer to Form #4300.

K-Factor

The K-factor represents the number of output pulses transmitted per gallon of fluid passing through the turbine meter. Each turbine has a unique K-factor. However, turbine meters are not functionally consistent throughout the full flow range of the meter.

There are several forms of "friction" inherent in turbine meters that retard the rotational movement of the turbine rotor. These frictional forces include: magnetic drag, created by electromagnetic force of pick-up transducers; mechanical drag, due to bearing friction; and viscous drag, produced by flowing fluid. See charts below.

As flow increases, the frictional forces are minimized and the free-wheeling motion of the turbine rotor becomes more linear (proportional to flow). The K-factor becomes relatively constant and linear throughout the balance of the linear flow range. This is approximately a 10:1 turndown ratio from the maximum flow rate down to the minimum flow rate.

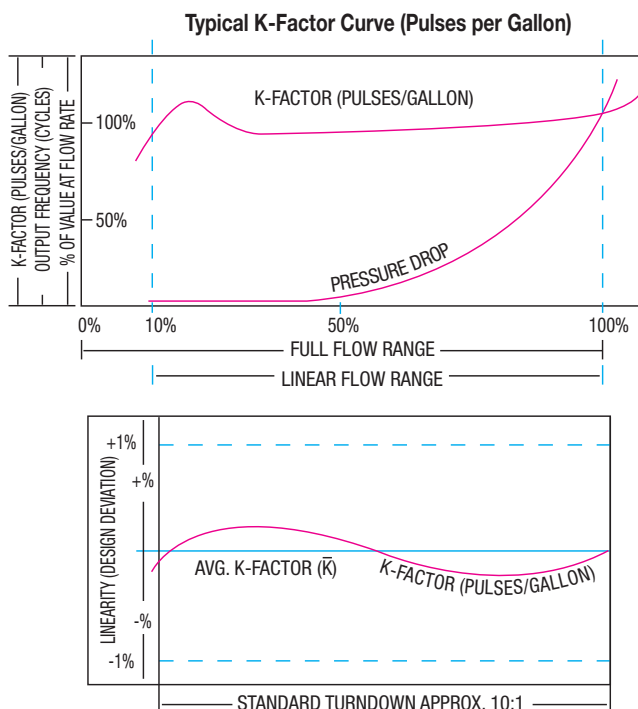

FloClean Flow Meter Part Numbering Information

B 1 6 A - **A** -

3-A Sanitary rating
A - COP / SOP

Ferrule Size
(see chart below)
0 - 0.984"
1 - 1.984"
2 - 3.047"

Bearing Material
A - Ni Bindery
Tungsten Carbide

Pick-up Option
0 - NEMA 6 Magnetic
1 - NEMA 6 Magnetic w/Pre-Amp
2 - Magnetic**
3 - Magnetic w/Pre-Amp**
4 - Active Sensor (B220-950) 4-20 mA**
6 - High Temp**
8 - Active Sensor (B220-951) 0-5 VDC**
9 - None

Meter Body Hub
A - With Hub*
B - No Hub

Calibration
A - 5 Point (standard)
B - 10 Point
C - 20 point

Flow Range
(see chart below)
03 - 0.6 - 3.0 GPM
05 - 0.75 - 7.50 GPM
07 - 2.0 - 15.0 GPM
08 - 3.0 - 30.0 GPM
10 - 5.0 - 50.0 GPM
15 - 15.0 - 180.0 GPM
20 - 40.0 - 400.0 GPM

* 1/2" NPT hub for Body Size 0; 1" NPT hub for Body Sizes 1 and 2
**Indoor use only

FloClean Size Chart

Ferrule Size	FLOW RANGE		K-factor Pulses/Gal	Repair Kit Part number
	GPM	LPM		
0.984"	0.6 - 3.0	2.3 - 11.4	20,000	B16A-K03A
0.984"	0.75 - 7.50	2.8 - 28.4	13,000	B16A-K05A
0.984"	2.0 - 15.0	7.5 - 56.8	2,750	B16A-K07A
1.984"	0.75 - 7.50	2.8 - 28.4	13,000	B16A-K05A
1.984"	2.0 - 15.0	7.5 - 56.8	2,750	B16A-K07A
1.984"	3.0 - 30.0	11.4 - 113.5	2,686	B16A-K08A
1.984"	5.0 - 50.0	19.0 - 190.0	870	B16A-K10A
1.984"	15.0 - 180.0	56.8 - 681.4	330	B16A-K15A
3.047"	40.0 - 400.0	151.4 - 1514.2	52	B16A-K20A

FloClean Dimensions

Inches (mm)

Ferrule Size Part No.	A	B	C
0	3.00 (76.2)	1.46 (37.1)	0.984 (25.0)
1	4.00 (101.6)	2.00 (50.8)	1.984 (50.4)
1*	6.25 (158.8)	2.33 (59.2)	1.984 (50.4)
2	6.50 (165.1)	3.20 (81.3)	3.047 (77.4)

* 15.0 - 180.0 GPM flow range only.

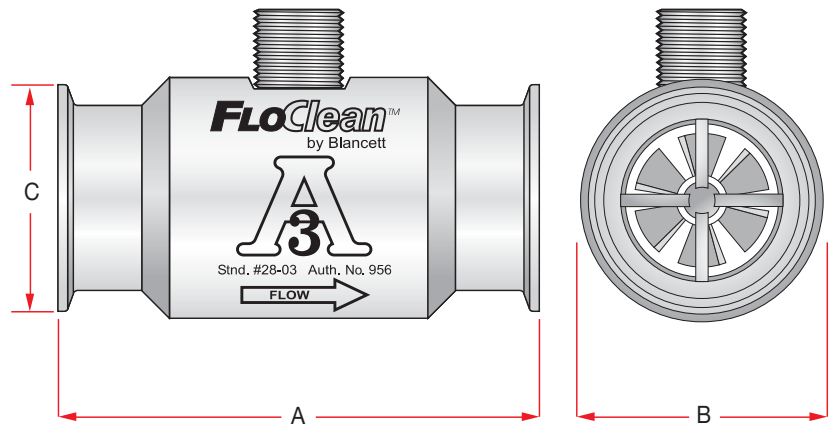

B2800 Flow Monitor

- Microprocessor-based flow monitor and totalizer
- Use with Blancett turbine flow meters as well as other flow meters with a frequency output
- Battery (1.5 VDC) and loop-powered (4-20 mA) versions
- Meter, remote, panel and swivel mounting options
- Hand-held and explosion-proof models also available
- CSA and CE approved
- Class I, Division 1 (Intrinsically Safe) certification



K-Factor Scaler Frequency Divider

- Scales turbine meter output to desired engineering units
- Amplifies turbine meter pulse output
- Converts frequency outputs into recognizable units for PLCs and other devices
- Switch-selectable or programmable versions available
- CSA approved



F to I / F to V Intelligent Converter

- Converts turbine frequency output into scaled analog output
- Linearized output capability
- Choice of 4-20 mA or 0-5 VDC output
- Enables integration with data acquisition devices
- Frequency measurement accuracy $\pm 1\%$
- CSA approved



Blancett

Flow Meters

■ 8635 Washington Avenue, Racine, WI 53406-3738 U.S.A.

■ Toll Free: 800-235-1638 Technical Toll Free: 877-722-4631

Tel: 262-639-6770 Fax: 262-639-2267

■ E-mail: info@blancett.com

BLANCETT is a registered trademark of Racine Federated Inc.
FloClean is a trademark of Racine Federated Inc.

© 2008 Racine Federated Inc., all rights reserved.
Printed in USA 9/08 Form No. 1600