

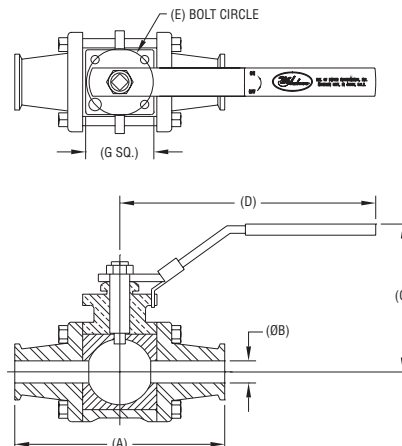

Series BV3HL Three-Piece Sanitary Ball Valve

Specifications - Installation and Operating Instructions

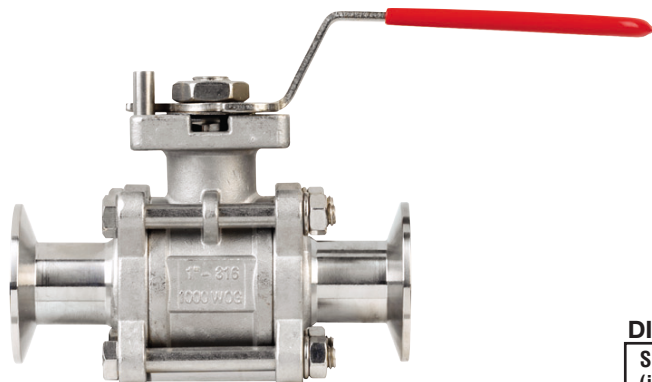

DIMENSIONS

Size (in.)	ISO 5211	A (in.)	B (in.)	C (in.)	D (in.)	E (in.)	G (in.)	Cv	Torque (in-lbs)	Weight lbs (kg)
1/2"	F03-F04	4.33	0.37	2.05	3.94	1.42/1.65	1.46	14	60	1.4 (0.64)
3/4"	F03-F04	4.68	0.63	2.24	5.16	1.42/1.65	1.46	45	80	2.0 (0.91)
1"	F04-F05	4.88	0.87	2.36	5.16	1.65/1.97	1.87	81	100	2.9 (1.3)
1-1/2"	F05-F07	5.55	1.37	3.54	7.36	1.97/2.76	2.20	215	380	5.7 (2.6)
2"	F05-F07	6.37	1.87	5.51	7.36	1.97/2.76	2.20	410	450	9.0 (4.1)
2-1/2"	F07	7.76	2.07	5.91	10.24	2.76	3.15	618	650	19.3 (8.8)
3"	F07	9.02	2.87	6.10	10.24	2.76	3.15	940	900	31.2 (14.2)
4"	F10	9.49	3.83	7.09	11.24	4.02	4.26	1840	1632	43.7 (19.8)

The Series BV3HL Three-Piece Sanitary Ball Valve provides easy replacement of gaskets, seals, and seats without any special tools. The swing-out design of the valve allows for the center section of the valve body to be replaced while leaving the ends clamped in place if necessary.

The BV3HL uses a cavity filled design, which means that the ball can remain completely enclosed by the pure TFE seats, eliminating the chance of product entrapment. Combined with an investment cast 316L stainless steel casting, this series of valve is ideal for food, beverage, semi-conductor, or pharmaceutical applications. Superior leak protection is accomplished by using a live-loaded packing system featuring belleville washers. An ISO 5211 mounting pad is provided for easy automation.

OPERATION

Manual Operation - To open or close the valve, turn the handle 90° (1/4 turn). Valve in OPEN position: the handle is parallel (in line) with the valve or pipeline. Valve in CLOSED position: the handle is perpendicular (crossed) with the valve or pipeline.

Automated Operation - Valves with actuators should be checked for stem alignment. Most applications are direct mount to the actuator, greatly reducing any sideload or increased torque. Make sure that all insert adapters are properly placed on the valve stem and fully engaged in the actuator.

SPECIFICATIONS

Service: Compatible liquids and gases.

Body: 3-piece.

Line Size: 1/2" to 4".

End Connections: Tri-Clamp (liner meets BS 4825, part 3).

Pressure Limits: 1000 psi (69 bar) WOG.

Wetted Materials:

Body, Ball, End Caps: CF8M stainless steel.

Stem: 316 stainless steel.

Stem Seal: Viton®.

Seats, Body Seal, Thrust Washer, Packing: PTFE.

Temperature Limits: -40 to 450°F (-40 to 232°C) CWP. 297°F (147°C) steam maximum.

Other Materials: 304 stainless steel, vinyl.

INSTALLATION

General Information for On-Site Installation - The valve may be fitted in any position in the pipeline. For automated operation, W.E. Anderson does recommend that the valve and actuator be installed vertically in case of valve leakage, although this is not necessary for proper operation of the valve. To prevent damage to the seats and ball surface, the pipeline must be flushed so that it is free of dirt, burrs and welding residues before installing the valve.

Installation of Clamp End Valves - Use the proper clamp and O-ring for pressure range of application. Place the O-ring into the O-ring groove on the clamp end. Slide the valve between the clamp fittings while making sure that the O-ring remains in place. Install the clamp over both valve ends and clamp fitting to insure alignment. Tighten both clamps on each valve end. Check proper operation of valve (manually or with the actuator).

Disassembling and Cleaning the Valve -

CAUTION: Ball valves can trap fluids in the ball cavity when it is in the closed position. If the valve has been used with hazardous media, it must be decontaminated before disassembly or handling.

WARNING: All persons involved in the removal or disassembly of the valve should wear protective gear such as eye and face protection, gloves, etc.

Relieve the line pressure. Place the valve in the half-open position and flush the line to remove any hazardous material(s) from the valve.

Replacing the Thrust Washer, Packing, and Seats - A repair kit is available for all valves comprising: seats, body seal, stem seal, thrust washer, and stem packing.

NOTE: The Series BV3HL Sanitary Ball Valve is designed with Belleville washers for automatic wear compensation. If there are signs of leakage from the stem, it is time to replace the stem packing and thrust washer.

Before replacing the thrust washer, seats, and packing, the pipeline must be depressurized. Maintenance, removal and replacement of seats and seals is simple even if the valve is installed in line. By removing three of the body bolts and loosening the fourth bolt, the valve body can be swung out of line (see illustration 1.1). Seats, seals, gaskets and balls can be replaced without disturbing the pipe alignment.

Bolt Tightening Specifications - The body bolts on the valve must be tightened evenly. Tighten the bolts by hand, then use a wrench to tighten bolts in diagonal opposition. See chart 1.2 for bolt torque specifications.

WARRANTY

The Series BV3HL Sanitary Ball Valve is warranted from defects in materials and workmanship for (1) year from the date of purchase. In the unlikely event the valve should fail, the unit can be returned to the factory for warranty repair if the warranty period has not expired. Contact our customer service department for an RGA number and to set up the return.

ILLUSTRATION 1.1: Swing-out Design

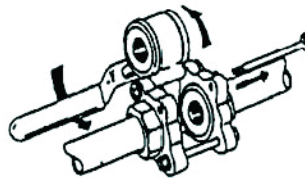

CHART 1.2: Bolt Torques

Valve Size	Body Bolt Torque (IN LBS)
1/4"	44
3/8"	44
1/2"	53
3/4"	62
1"	89
1-1/2"	186
2"	230
2-1/2"	336
3"	487

Viton® is a registered trademark of E.I. du Pont de Nemours and Company.

©Copyright 2005 Dwyer Instruments, Inc.

Printed in U.S.A. 5/05

FR# R2-443348-00

W.E. ANDERSON DIV., DWYER INSTRUMENTS, INC.
P.O. BOX 358 • MICHIGAN CITY, INDIANA 46361 U.S.A.

Phone: 219/879-8000
Fax: 219/872-9057

www.dwyer-inst.com
e-mail: info@dwyer-inst.com