



Model
V10
&
V11

FLOTECT® Mini-Size Flow Switch

Proof of Flow or No Flow in 1/2 to 2" Pipe,
Low Cost, Leak Proof Body, Weatherproof



Flow

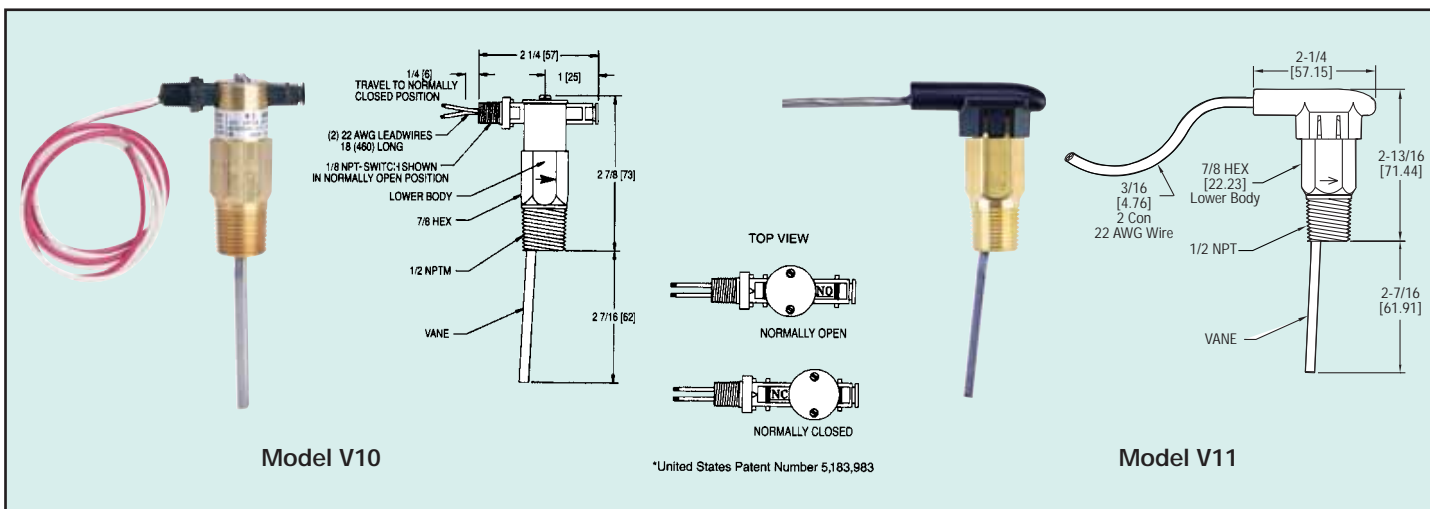

Designed to provide an inexpensive, reliable unit to monitor the presence or absence of flow in a system. The V10 and V11 flow switches are used to monitor unattended equipment and protect it from costly damage. The V10 flow switch utilizes a rugged, hermetically sealed reed switch which is encapsulated in a polypropylene switch housing that fits into a standard heavy duty leak proof brass body or optional 303 SS body. The patented switch adjustment* allows the user to change the switch to Normally Open (NO) or Normally Closed (NC) in the field merely by loosening two screws. The switch housing is located outside the process media, making switch change-over or maintenance easy without interruption of process flow.

The V11 Flotect® flow switch takes our very popular V10 design and adds rugged, integral electrical wiring. The one-piece PBT switch housing snaps onto the body and the wiring is epoxy sealed making the switch weatherproof, meeting NEMA 4 standards. The 22 AWG cable used is UV resistant, flame retardant, and comes standard 6 feet in length. This unique design eliminates the need for running conduit between the switch and panel, lowering installation costs.

A full size, trimmable stainless steel vane is provided with a removable laminated template. This template is calibrated for brass or ductile iron reducing tees and forged steel straight tee/bushing combinations. Allows for field installation in pipelines from 1/2" to 2" diameter. A table with approximate actuation and deactivation values is provided below.

Cold Water Flow Rates Approximate actuation/deactuation GPM upper, LPM lower				Air Flow Rates Approximate actuation/deactuation SCFM upper, LPM lower			
Pipe	Trim	N.O.	N.C.	Pipe	Trim	N.O.	N.C.
1/2"	L	2.6/2.3 9.8/8.7	2.6/2.5 9.8/9.5	1/2"	L	10.3/8.8 291.7/250	10.2/9.2 288/260
3/4"	J	3.1/2.7 11.7/10.2	3.1/2.8 11.7/10.6	3/4"	J	13/11.6 368.3/328	12.9/11.6 365/328
1"	H	4.8/4.5 18.2/17	4.8/4.4 18.2/16.7	1"	H	19.2/17.6 543.3/498	18.9/17.6 535/498
1 1/4"	E	6.2/5.6 23.5/21.2	6.1/5.6 23.1/21.2	1 1/4"	E	24.8/22.2 701.7/628	24.5/22.5 693/637
1 1/2"	C	8.2/7.7 31/29.1	8.2/7.7 31/29.1	1 1/2"	C	33.4/31.2 946.7/883	33/30.6 935/867
2"	Full	9.5/9.1 36/34.4	9.5/9 36/34.1	2"	Full	50.2/48.4 1422/1370	50.2/47.7 1422/1352

SPECIFICATIONS

Service: Compatible gases or liquids.

Wetted Materials:

- Vane: 301 SS.
- Body: Brass or 303 SS.
- Pin and Spring: 301 SS, 302 SS, and 316 SS.
- Magnet: Ceramic 8.

Temperature Limit: V10: 200°F (93°C), V11: 190°F (88°C).

Pressure Limit: Brass body: 1000 psig (69 bar), 303 SS body: 2000 psig (138 bar).

Switch Type: SPST hermetically sealed reed switch. V10: Field adjustable for normally open or normally closed.

Electrical Rating: 0.5A @ 30VAC, 1.5A @ 24VDC.

Electrical Connections: V10: 22 AWG, 18" (460 mm) long, V11: 22 AWG, 6' (1.83 m) long. Rated 392°F (200°C). 300V. Flame retardant extruded FEP insulation and overall shield.

Conduit Connection: V10: 1/8" male NPT.

Process Connection: 1/2" male NPT standard. Contact factory for other options.

Mounting Orientation: Switch can be installed in any position but the actuation/deactuation flow rates are based on horizontal pipe runs and are nominal values.

Set Point Adjustment: Vane is trimmable.

Weight: V10: 4.5 oz (0.13 kg), V11: 5.8 oz (0.165 kg).

Agency Approvals: V10: CE, UL and CSA; V11: UL.

Switch Enclosure: V10: Polypropylene, V11: Polybutylene terephthalate (PBT).

Model Number	Body Material	Switch Configuration
V11-BNOA-6	Brass	Normally Open
V11-BNCA-6	Brass	Normally Closed
V11-SNOA-6	303 SS	Normally Open
V11-SNCA-6	303 SS	Normally Closed
V10	Brass	Normally Open or Closed
V10SS	303SS	Normally Open or Closed