



M600
Revision D
April 2010

6600 Series Magnetic Flowmeter



INSTALLATION, OPERATION & MAINTENANCE MANUAL

USING THIS MANUAL

This manual is designed to assist in installing, operating, and maintaining the 6600 Series Magnetic Flowmeter.

SAFETY INFORMATION

Before installing the 6600 Series Magnetic Flowmeter, please read these instructions. Familiarize yourself with the requirements and functions. If any questions or problems arise please contact Niagara Meters Applications at 1-800-778-9242.

Ensure that all personnel involved with operating this device are suitably qualified. Observe all local and national electrical codes for the wiring of this device.

NOTE: Manufacturer's instructions and the National Electrical Code (ANSI/NFPA 70) must be followed when installing this equipment. Tampering or replacement with non-factory components may adversely affect the safe use of the system.

DISCLAIMER: In order to continuously improve quality, Venture Measurement Co. LLC reserves the right modify the technical content without prior notice.

Responsibility as to the suitability and intended use of the instrument lies solely with the operator.

Improper installation, operation or miss-use of the instrument may result in loss of warranty.

Symbols

The following symbols are used in this operation manual or instrument and this should be interpreted correctly as given against each symbol.







Number	Symbol	Description
1		Direct Current
2		Alternating Current
3		Earth (Ground) Terminal
4		Protective Conductor Terminal
5		Caution (Refer to accompanying documents)
6		Caution (Risk of electric shock)

TABLE OF CONTENTS

1.0 PRODUCT DESCRIPTION		PAGE
1.1	Function	1
1.2	Applications	2
1.3	Principal of Operation	2
1.4	Model Code Identification	5
1.5	Technical Specifications	6
1.6	Dimensions	9
2.0 HANDLING & STORAGE		
2.1	Inspection and Handling	15
2.2	Storage	17
3.0 MECHANICAL INSTALLATION		
3.1	Guidelines	17
3.2	Mounting	19
4.0 ELECTRICAL WIRING		
4.1	Guidelines	21
4.2	Connection Information / Wiring Diagram	22
5.0 SET-UP & PROGRAMMING		28
6.0 MAINTENANCE		38
7.0 DIAGNOSTIC MESSAGES		39
8.0 TROUBLESHOOTING		40

1.0 PRODUCT DESCRIPTION

1.1 Function

The 6600 Series is a low cost, Electromagnetic Flowmeter that combines ease of use and reliability to accommodate a wide range of applications.

In the standard 6600 Series of Magnetic flowmeters, the SENSOR and the ELECTRONICS form one mechanical entity. In the optional high temperature version for temperatures up to a maximum of 248° F (120° C) or for fluid temperatures exceeding 176° F (80° C), the electronics are remotely mounted, and can be installed up to 330 feet away from the sensor depending on conductivity.

The SENSOR consists of a metering tube, electrodes and coils. The electrodes and coils are in a welded fully encapsulated sheet metal enclosure that is filled with polyurethane. This prevents the internals of the sensor from becoming exposed to moisture and environmental conditions. The SENSOR rating with integrally mounted electronics is IP67 (protection against entry of dust and low pressure jet of water from all directions, NEMA 4X), with Remote Electronics IP67 (protection against entry of dust and submersion in water, NEMA 6P).

The conditioning ELECTRONICS circuitry is housed in a cast aluminum box with IP67 (protection against dust and limits submersion to 3.2feet/1 meter, NEMA 6) protection. The termination of the electronics is given in an adjacent cast aluminum housing with ½-inch NPT fittings for the required interface cables

The flanged meter is available from 1/2 to 24 inch sizes. Hastelloy Stainless Steel electrodes (150#,carbon steel flanges) are standard, but several other electrode materials such as 316SS, Titanium, Monel, Platinum Rh etc. are available.

The 4-20 mA output proportional to flow can be fed to a PLC, DCS or remote mounted indicator. An optional 24 V DC pulse or frequency output can be connected to external devices such as a totalizing counter.

The complete instrument consists of a sensor and a controller.

Sensor: The sensor consists of the metering pipe, electrodes and magnetic coils. It is encapsulated in a fully welded sheet steel enclosure that is filled with polyurethane to prevent exposure to moisture and environmental conditions.

Controller: The controller contains the electronics that is used for driving the magnetic coils, conditioning the electrode signal and providing the outputs. It may be mounted integral with the sensor or on a wall.

Compact Version: In the compact unit, the controller and the sensor form a single mechanical entity.

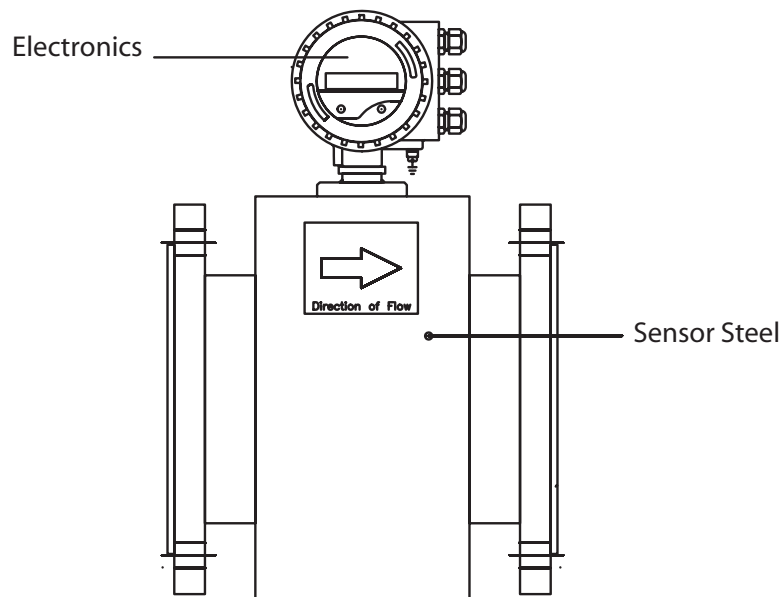

Remote Version: In the remote version, the controller and the sensor are separate and are interconnected using a special cable that is supplied with the instrument.

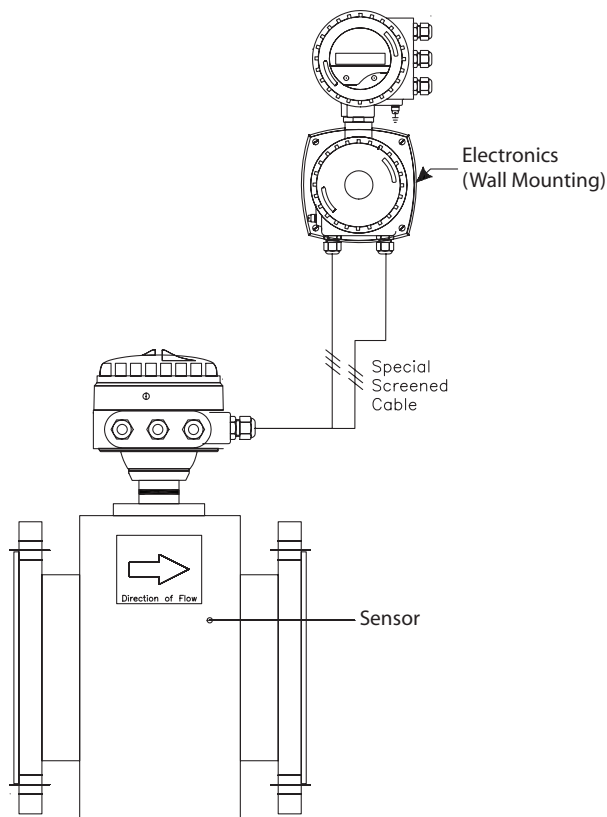

1.2 Applications

The electromagnetic flowmeter is used to measure the flow of conductive liquids and slurries as low as 5 Micro Siemens (including corrosive and abrasive) in closed pipes. The performance of the instrument is not affected by the properties of the material such as corrosiveness, viscosity, pressure, density, acidity and alkalinity. It can measure the flow of liquids, pastes and slurries in water, wastewater, chemical, fertilizer, dairy, food, beverage, pharmaceutical, medical, petrochemical, iron, steel, paper, mining and agricultural industries, etc.

They are used to measure water flow cooling in steel and power plants. They have the ability to measure flow of clean water, effluent, sludges, etc., in pollution and environmental control.

These meters offer an obstructionless, maintenance free alternative to mechanical flow devices. The 6600 series of electromagnetic flowmeters offer the user economical flow monitoring using pulsed DC technology. The design allows quick and easy installation without the need for skilled personnel and is virtually maintenance free.

1.3 Principle of Operation

A conductive fluid flowing through a magnetic field generates a voltage proportional to its' velocity. Electrodes sense the voltage for transmission to the electronic converter. A simple calculation using the cross sectional area of the flowmeter provides the volumetric flow.

The principle of operation is based on Faraday's law of Electromagnetic Induction. In an Electromagnetic flowmeter, the liquid passing through the device represents a conductor moving through a magnetic field. It induces a voltage perpendicular to both the magnetic field and the direction of flow. The voltage is linearly proportional to the mean velocity as is represented in the following empirical equation:

$e = l \cdot B \cdot v$ Where,
 e = Induced Voltage
 l = Conductor Length
 B = Magnetic Field Strength
 v = Velocity of the conductive fluid

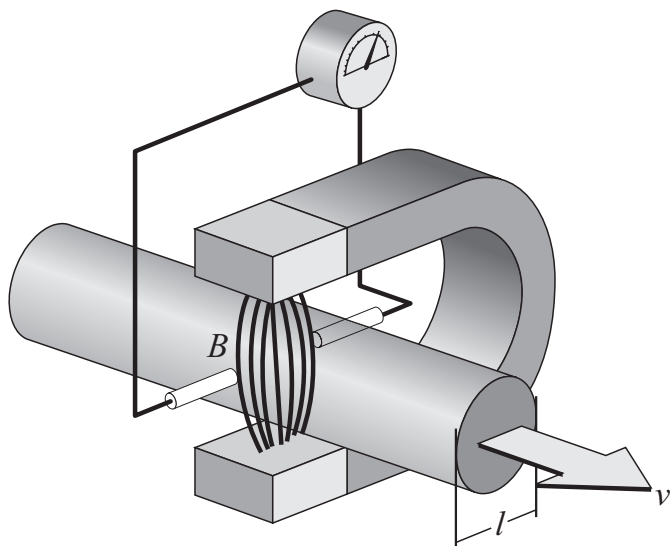

The voltage generated is detected by a pair of insulated electrodes as the conductive liquid moves through the magnetic field.

l : The length corresponds to the distance between the electrodes. The internal distance between the electrodes inside the measuring pipe remains constant for a particular model.

B : The strength of the magnetic field is constant by design for a particular model and meter size.

e : The induced voltage is therefore linear in a relation with the pipe internal diameter, strength of the magnetic field and the mean flow velocity. With l and B being constant for a particular size, the voltage generated (e.m.f.) is directly proportional to the mean flow velocity.

$$\text{Voltage } e \text{ (e.m.f. generated) } \propto v \text{ (velocity)}$$

$$\text{Since, } v = \text{Flow Rate} / \text{Cross sectional area} \Rightarrow Q \text{ in ft}^3/\text{min} / (\pi \times D_i^2 / (4 \times 144))$$

$$\text{Where } D_i = \text{Internal Pipe Diameter Inches}$$

Substituting in the main equation:

$$e = l \times B \times Q \text{ in ft}^3/\text{min} / (\pi \times D_i^2 / (4 \times 144)) \Rightarrow Q \times l \times B \times 4 \times 144 / (\pi \times D_i^2)$$

↑ Variable ↑ Constant

Therefore, for a given nominal diameter or cross section, the e.m.f. generated is proportional to flowrate, i.e.

$$e \text{ (e.m.f. generated) } \propto Q \text{ (volumetric flowrate)}$$



This equation holds true only when the pipe is completely filled, as we are assuming that the entire section of the pipe is always full. The measurement is not reliable if this condition is not fulfilled.

For any electromagnetic flowmeter to work reliably, it is therefore extremely important that the measuring tube is completely full, which by default can be achieved easily through vertical mounting of the flowmeter. Hence a vertical upstream installation is preferred.

Electromagnetic flowmeters can be installed in vertical, angle or horizontal mounting positions, as long as the pipe remains completely full. The electrode axis in such installations must be kept in the horizontal plane.

To increase the signal to noise ratio, the magnetic field is pulsed. During the pulse period, voltage is induced at the electrodes. During the off period, the generated voltage is zero. During this off pulse, any signal voltage is interference (noise). This voltage is subtracted out and stored by the electronic circuitry (auto zero). During the pulse period the stored interference voltage noise is subtracted and cancelled out by the electronics circuitry yielding only the true generated signal that is being induced by the fluid moving through the meter. The auto zero occurs several times a second insuring an automatic positive reference as to zero flow.

The induced voltages are amplified using differential amplifiers with high input impedances to minimize the effect from any electrode coating. The amplifier gain is adjusted using R-ref in such a way that the flowmeter gives a 20 mA output current for maximum flow range. The current output can be used for remote indication and or recording purposes.

To compensate for any fluctuations of the magnetic field intensity, the current passing through the coils is measured. The magnitude of this current increases or decreases the frequency output on the amplifier card. This frequency is used to generate the 4-20 mA current output. Pulse Outputs and Relay Outputs corresponding to High and Low Alarms are generated by the micro controller.

All program data is stored in NVRAM. Even in the case of power failure, programmed parameters are retained by the NVRAM.

Data entry is accomplished by activating Hall Effect switches using a magnetic commander.

1.4 Model Code Identification

Model 6600 Magnetic Flowmeter

Model # 66 - - - - -

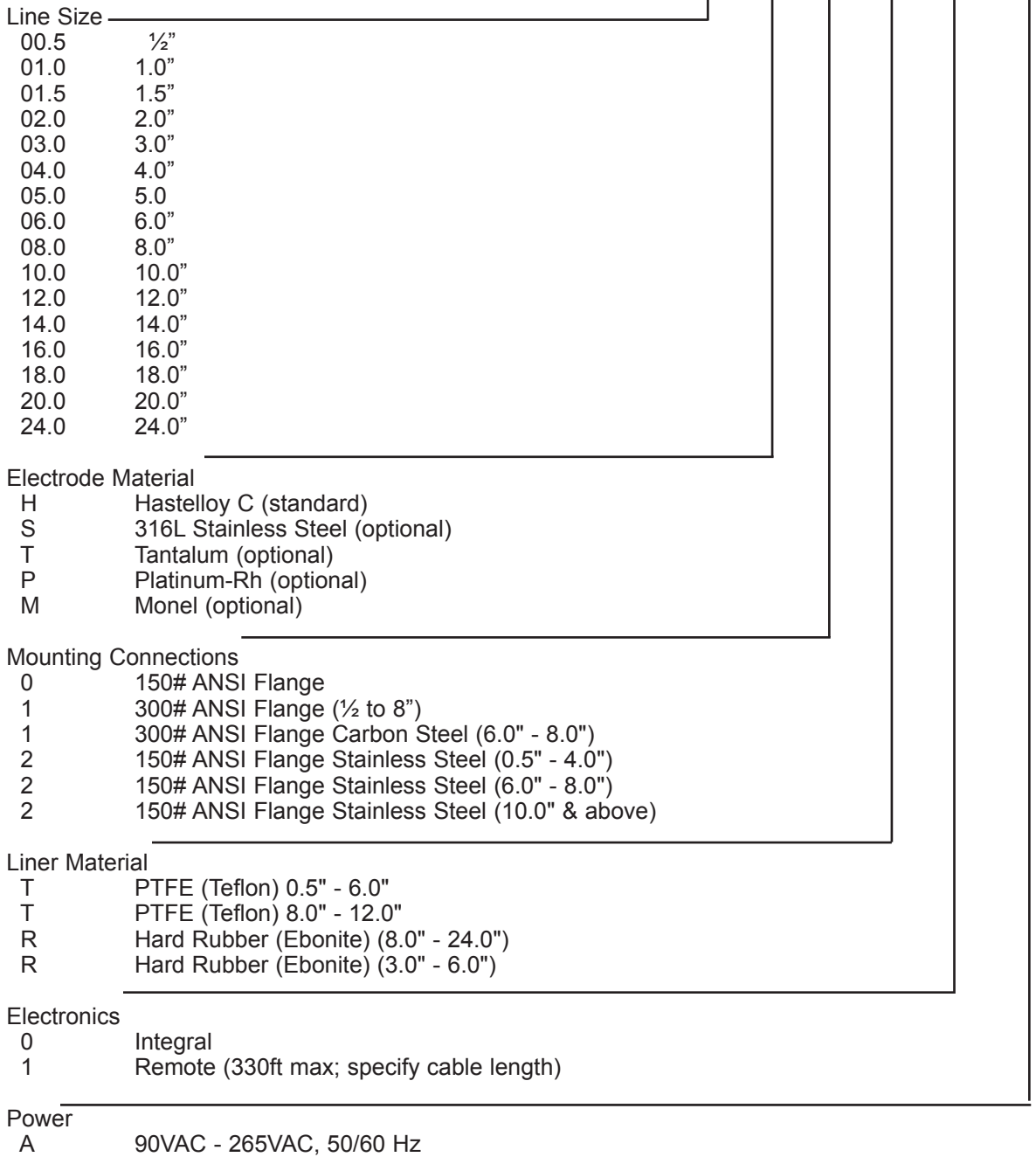

If you require more than the standard 15ft cable, order part number 60524P010.

Other materials of construction available, Consult Factory.

1.5 Technical Specifications

Functional Specifications

Fluid Types	Conductive Liquids > 5µS/cm
Fluid Pressure	150 PSI, Consult factory for higher ratings
Fluid Temperature	PTFE (Teflon): -4 to 176 F Integral PTFE (Teflon): -4 to 248 F Remote Hard Rubber (Ebonite): 32 to 158 F
Vacuum Limits	Consult Factory
Low Flow Cut-Off	Set at 0.164 ft/sec(typical)
Magnetic System	Pulsed DC
Voltage	90VAC to 265VAC, 50/60 Hz
Outputs	<ol style="list-style-type: none"> Current - 4-20mA DC; 800 ohms max Pulse - Open collector 24 VDC; 200 ohms min load, programmable "on" time from 1 to 99msec. 1 Pulse = The least significant digit on the totalizer Frequency = 0-1000Hz 1000Hz = programmed full scale flow rate Relays - Two SPDT 2A @ 230VAC, #1 - for high flow or bi-directional #2 - for low flow or empty pipe Empty Pipe Detection also indicated as "EPD" on display Bi-directional Flow also indicated as "BDF" on display; forward (+) & reverse (-) indication with separate totalizers

Performance Specifications

Accuracy	+/- 0.5% of rate over 10:1 turndown ½" to 12" +/- 1.0% of rate over 10:1 turndown 14" to 24"
Repeatability	+/- 0.1% of full scale
Full Scale Flow	1.6 to 32 ft/sec
Response Time	2 sec
Velocity Range	0.16 to 32 ft/sec
Agency Approvals	FM3810 (General Purpose) for ½" to 24" FM3611 (Class 1 Div II, Group C&D) for ½" to 6"
Protection	IP 67 (1 meter immersion in water for 30 minutes)

Physical Specifications

Materials of Construction	
Liner	PTFE (Teflon): ½" to 12" Hard Rubber (Ebonite): 3" to 24"
Electrodes	Hastelloy C (standard) SS316L, Titanium, Platinum-Rh, and Monel (optional); Consult factory for more materials
Metering Tube	Not wetted - 304 SS
Coil Housing	Not wetted - Carbon Steel, Polyurethane painted
Flanges	Not wetted - Carbon Steel, Polyurethane Painted; SS304 (optional)
Electronics Housing	Not wetted - Cast Aluminum, Polyurethane painted
Connections and Mountings	
Mounting	Vertical, horizontal, or angle. Pipe must be full. Grounding rings not required.
Pipe Requirements	Upstream: 5 X ID Downstream: 3 X ID
Process Connections	ANSI Class 150 RF (standard) ANSI Class 300 RF (optional)

Electronics Specifications

Temperature	-4 to 140 F
Connections	½"NPT

Accuracy of Magmeters (Standard and Blind units) is defined as below:

Accuracy Limits

Flow Velocity 0.164 ft/sec to 32 ft/sec:	0.5% of Flow Rate	10:1TD for 0.5-12"
Below 1.64 ft/sec and up to 0.328 ft/sec:	1.0% of Flow Rate	10.1TD above 12"

Repeatability: 0.1% of Full Scale

Effect of Power Variations (at 90 to 265VAC) +/- 0.3% in error at 100% Flow Rate

Reference Conditions

Recommended Calibration Velocity:	6.56 ft/sec
Ambient Temperature:	77° F, +/- 3.6° F
Mains Variations:	+/- 2%
Warm up Time:	30 Minutes
Installation Inlet Length:	>10 x NB
Outlet Length:	>5 x NB

Sensor and electronics are grounded properly and sensor is centered in pipe.

Accuracy statement is based on frequency/scaled pulse output of Flow Meter taken after suitably dividing the frequency, avoiding any transaction error.

Magmeter Weight Chart

SIZE	NET WEIGHT IN LBS./KG	
	FLANGE SIZE	
	150#	300#
1/2"	22.04/10	22.04/10
1"	30.81/14	33.07/15
1-1/2"	35.27/16	41.89/19
2"	39.68/18	44.09/20
3"	59.52/27	68.34/31
4"	72.75/33	92.59/42
5"	99.2/45	125.66/57
6"	110.23/50	147.71/67
8"	121.25/55	176.37/80
10"	220.46/100	304.24/138
12"	286.6/130	405.65/184
14	357.15/162	511.47/232
16	429.9/195	623.9/283
18"	487.22/221	751.78/341
20"	694.46/315	1033.1/455
24"	826.73/375	1313.96/596

Flow Ranges

NOTE: Minimum flow; divide full-scale flow by 10. Full-scale can be set any where between the full-scale flow range given in the table below. Standard unit only.

Line Size (in)	Min. Meas. Flow (GPM)	Min. 20mA Setting (GPM)	Max. 20mA Setting (GPM)	Dim. "A" End to End Inches	Dim. "B" Width Inches	Dim. "C" Width Inches	Weight (lb)
0.50	0.14	1.40	25	8.268	6.457	7.047	22.04
1.00	0.40	4.00	80	8.268	6.457	7.047	30.81
1.50	1.00	10.00	195	8.268	6.457	7.047	35.27
2.00	1.50	15.00	310	8.268	6.457	7.047	39.68
3.00	4.00	40.00	790	11.204	8.78	9.213	59.52
4.00	6.00	60.00	1230	11.204	8.78	9.213	72.75
5.00	10.00	100.00	1980	13.386	13.661	14.09	99.2
6.00	14.00	140.00	2820	13.386	13.661	14.09	110.23
8.00	25.00	250.00	4975	13.386	13.661	14.09	121.25
10.00	39.00	390.00	7790	18.11	18.583	18.583	220.46
12.00	55.50	555.00	11095	19.291	20.784	20.784	286.6
14.00	76.00	760.00	15250	22.047	22.48	22.48	357.15
16.00	99.50	995.00	19900	24.016	25.472	25.472	429.9
18.00	126.00	1260.00	25200	25.984	27.362	27.362	487.22
20.00	155.50	1555.00	31100	25.984	28.465	28.465	694.46
24.00	220.00	2200.00	44900	31.102	32.992	32.992	826.73
20.00	155.50	1555.00	31100	25.984	28.465	28.465	694.46
24.00	220.00	2200.00	44900	31.102	32.992	32.992	826.73

1.6 Dimensional Drawing

Integral

*Dimensions (in./mm)

Nominal Size (ID)	A	B	C
.50/15	8.27/210	6.46/164	7.05/179
1.00/25	8.27/210	6.46/164	7.05/179
1.50/40	8.27/210	6.46/164	7.05/179
2.00/50	8.27/210	6.46/164	7.05/179
3.00/80	11.02/280	6.46/223	9.21/234
4.00/100	11.14/283	6.46/223	9.21/234
6.00/150	13.39/340	13.66/347	14.09/358
8.00/200	13.39/340	13.66/347	14.09/358

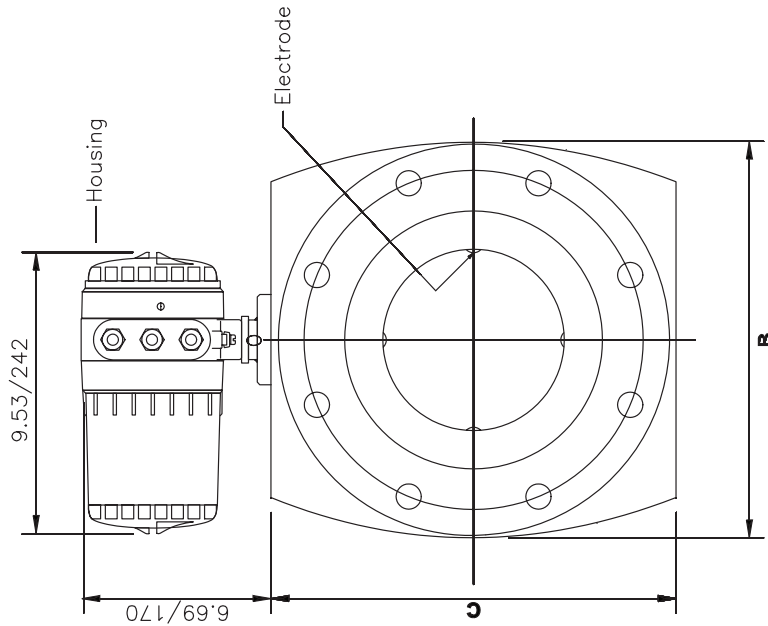
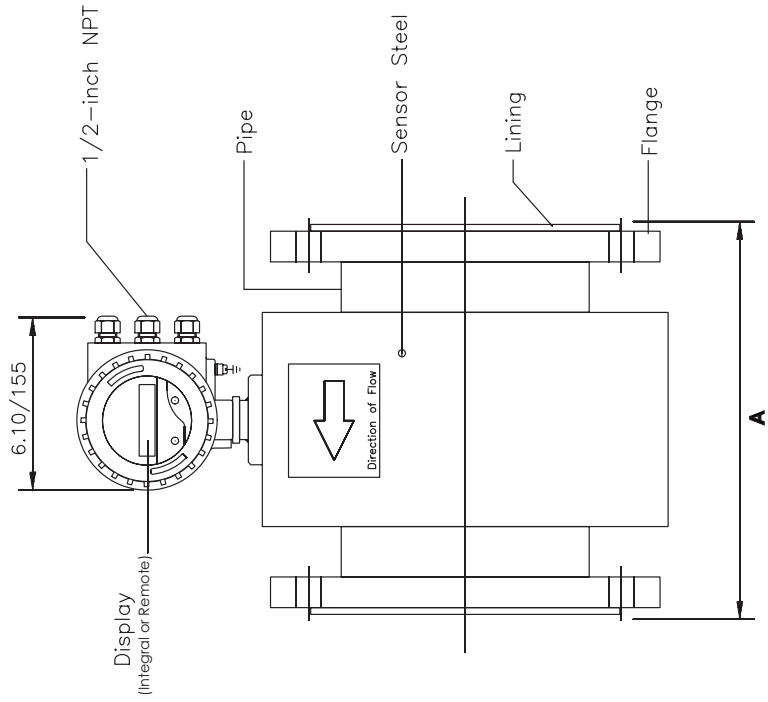

SK90018

A INIT. RELEASE		07-541	SE	JD	TITLE Mag 6000 Integral & Remote	
REVISIONS		ECN #	DATE	DATE	SCALE NONE	SIZE A
					PART SK90018	
					SHEET 1 of 4	

venture
MEASUREMENT
150 VENTURE BLVD.
SPARTANBURG, SC 29306

Integral

*Dimensions (in./mm)

Nominal Size (ID)	A	B
10.00/250	18.11/460	18.58/472
12.00/300	19.29/490	20.75/527
14.00/350	22.05/560	22.48/571
16.00/400	24.02/610	25.47/647
18.00/450	25.98/660	27.36/695
20.00/500	25.98/660	28.46/723
24.00/600	31.10/790	32.91/836

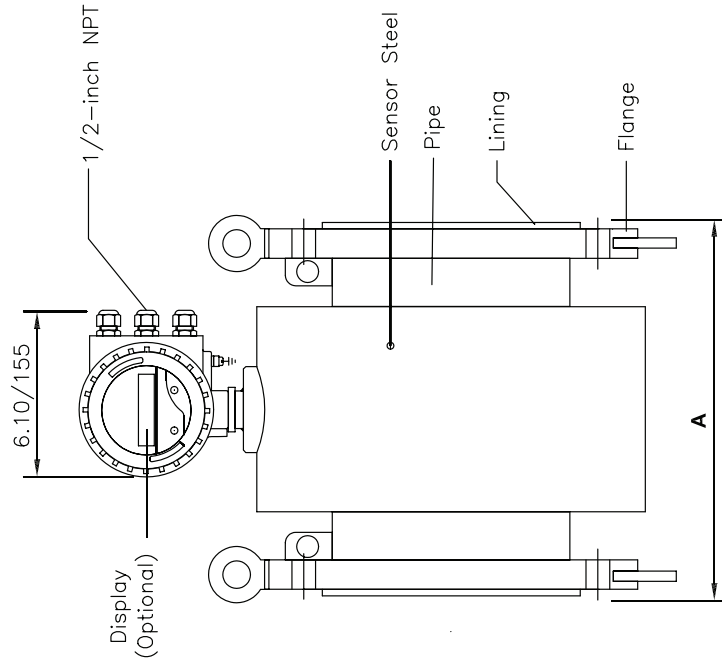
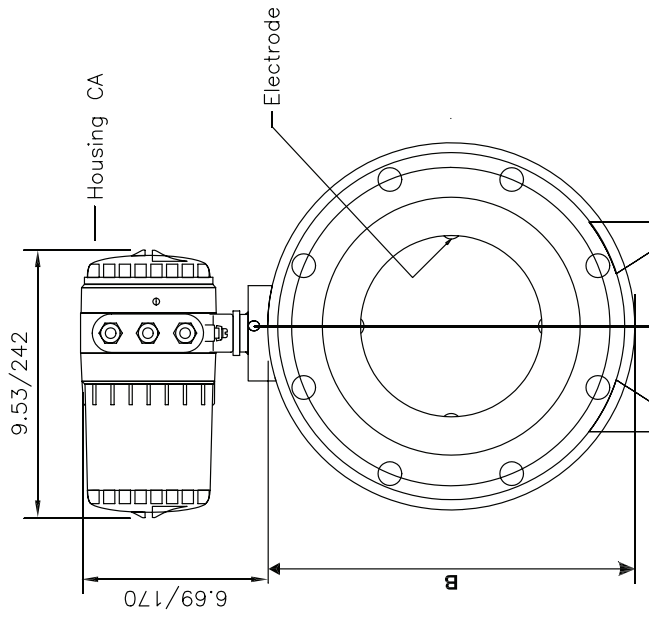

PART	SHEET
SK90018	3 of 4
	Rev A

SK90018

Remote

*Dimensions (in/mm)

Nominal Size (ID)	A	B	C
.50/15	8.27/210	6.46/164	7.05/179
1.00/25	8.27/210	6.46/164	7.05/179
1.50/40	8.27/210	6.46/164	7.05/179
2.00/50	8.27/210	6.46/164	7.05/179
3.00/80	11.02/280	6.46/223	9.21/234
4.00/100	11.14/283	6.46/223	9.21/234
6.00/150	13.39/340	13.66/347	14.09/358
8.00/200	13.39/340	13.66/347	14.09/358

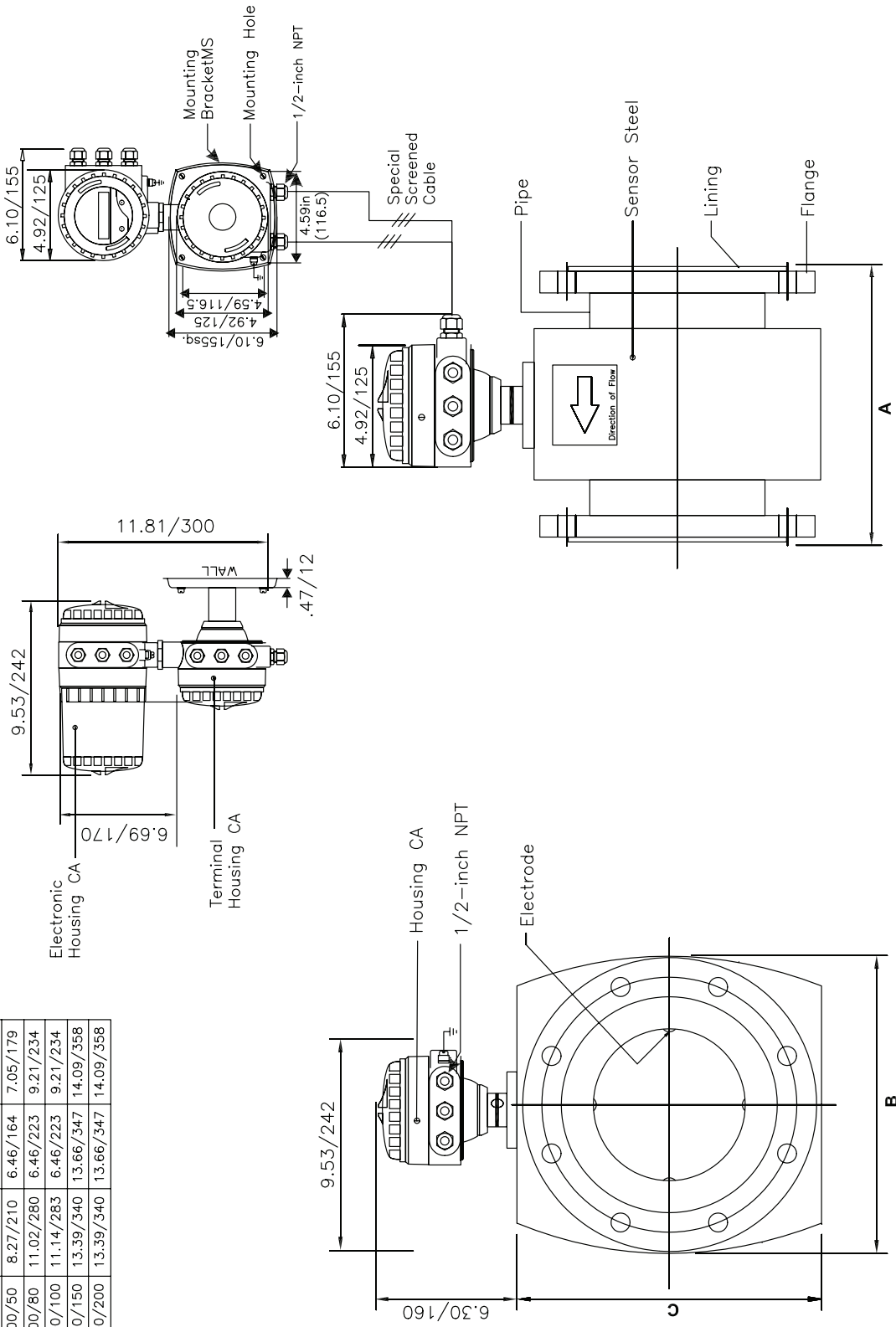

PART
SK90018

SHEET
2 of 4
Rev A

SK90018

Remote

*Dimensions (in./mm)

Nominal Size (ID)	A	B
10.00/250	18.11/460	18.58/472
12.00/300	19.29/490	20.75/527
14.00/350	22.05/560	22.48/571
16.00/400	24.02/610	25.47/647
18.00/450	25.98/660	27.36/695
20.00/500	25.98/660	28.46/723
24.00/600	31.10/790	32.91/836

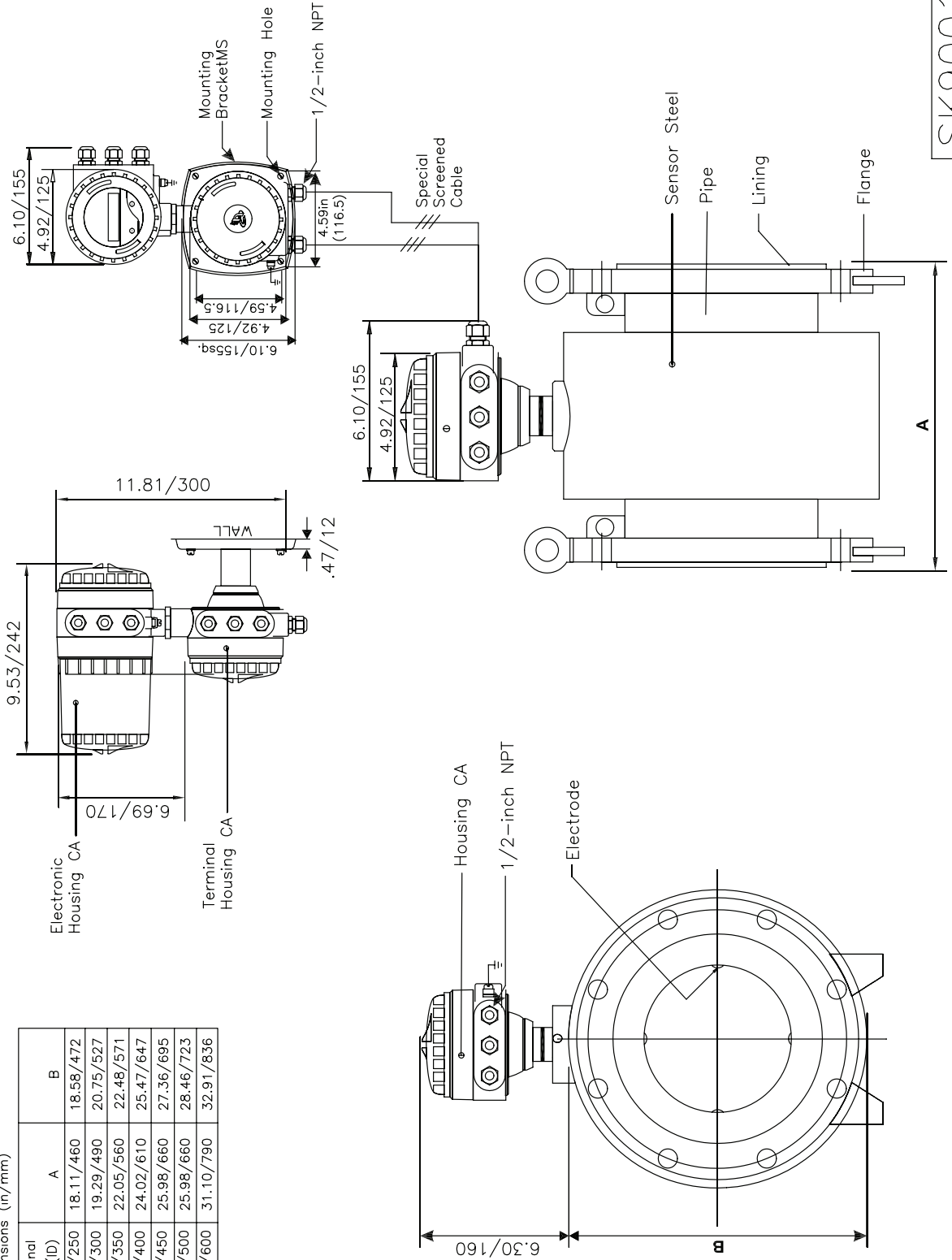

SK90018

PART	SHEET
SK90018	4 of 4
	Rev A

Wall Mounting Plate Assembly for Housing Type C & D

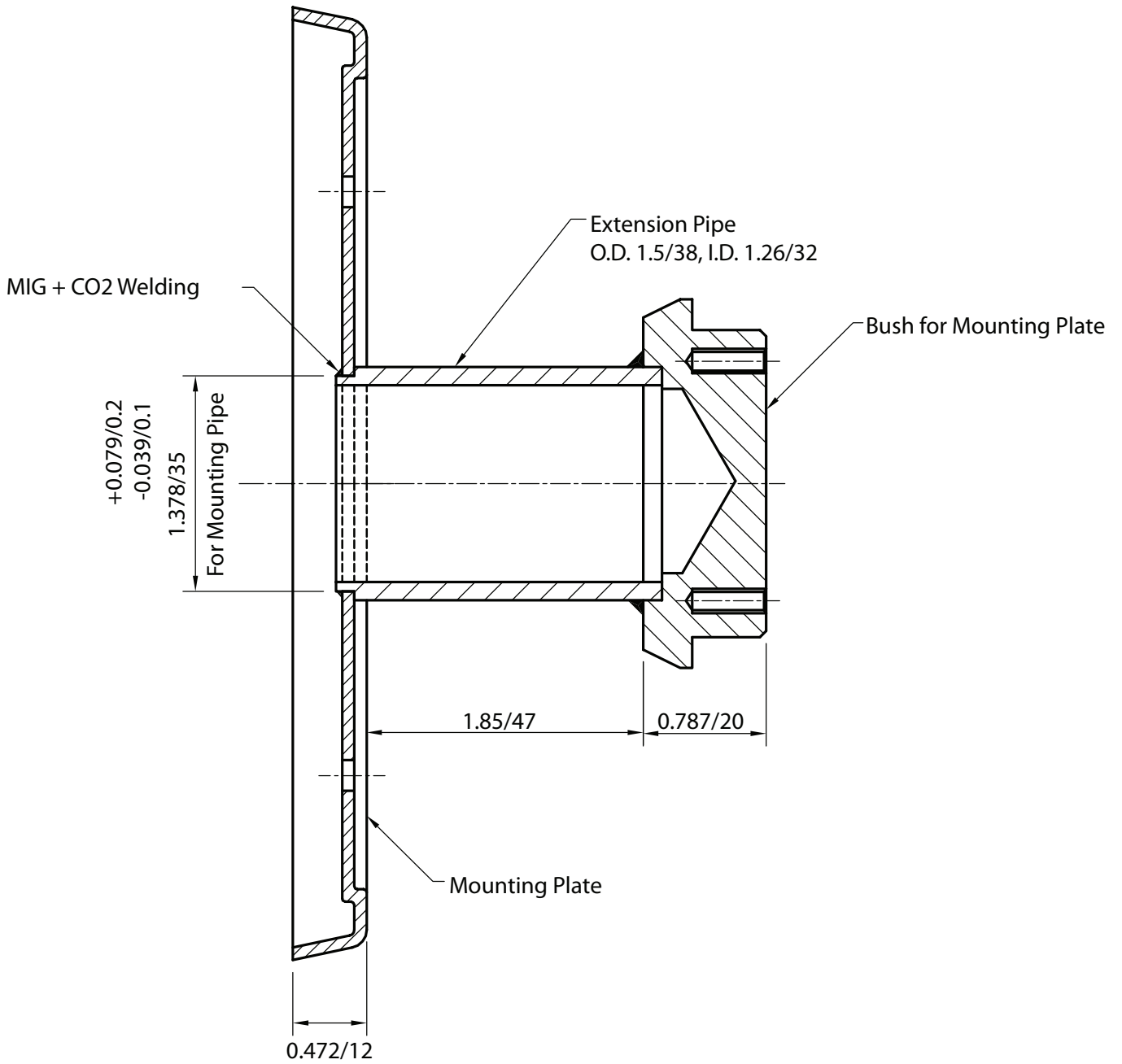

2.0 HANDLING & STORAGE

2.1 Handling and Installation

Read complete instructions before installing.

Unpacking: Care should be taken in removing the flowmeter from its carton. The flowmeter liner may be damaged if it comes in contact with rough surfaces or sharp objects and must be protected at all times. The meter has wooden protector plates on each flange to protect the liner. **Do not remove protective plates until you are ready to install the meter.** Read and observe all tags.

Considerations for installation: When selecting the installation site, the following should be taken into consideration.

The meter can be installed horizontally, angle or vertical. Before deciding the mounting position, note that it is essential the meter be filled with liquid at all times for its flow readings to be accurate. If there is a very low flow situation then the meter should be mounted in a vertical riser with the flow going upwards. In this manner, the pipe will always be full even if the flow goes down to a trickle.

Installation: In horizontal installations the meter should be in the lowest section of the pipe to assure a filled meter condition.

If you have local indication on your meter and the meter will be installed in a high location, the meter can be installed at a 45° angle by properly positioning the mating flanges on the pipe. This will allow you to read the rate indicator and totalizer more conveniently.

Good engineering practices should be followed in any metering installation. Placing the valve directly upstream of the meter is not recommended. A minimum of ten pipe diameters of straight pipe are required between the meter and a valve or pump.

The installation should be away from strong magnetic fields or other major sources of electrical interference.

Be sure all electrical entries into the unit are properly sealed to prevent moisture from entering the electronics enclosure.

If you are using remote electronics, the electronic unit may be mounted up to 330 feet away depending on liquid conductivity.

Installing the meter: There is a flow arrow on the meter housing. The meter should be installed so that the forward flow proceeds in the direction of the arrow.

Handling the Instrument

The instrument should be handled as shown in the following diagrams.

- A) For flow meter sizes less than 6 inches, use webbing slung around the process connections. Do not use chains as these could damage the instrument. Do not lift the instrument from the controller.



There is risk of injury if the instrument slips from the webbing. Hence, care should be taken to ensure that the instrument does not suddenly rotate about its axis.

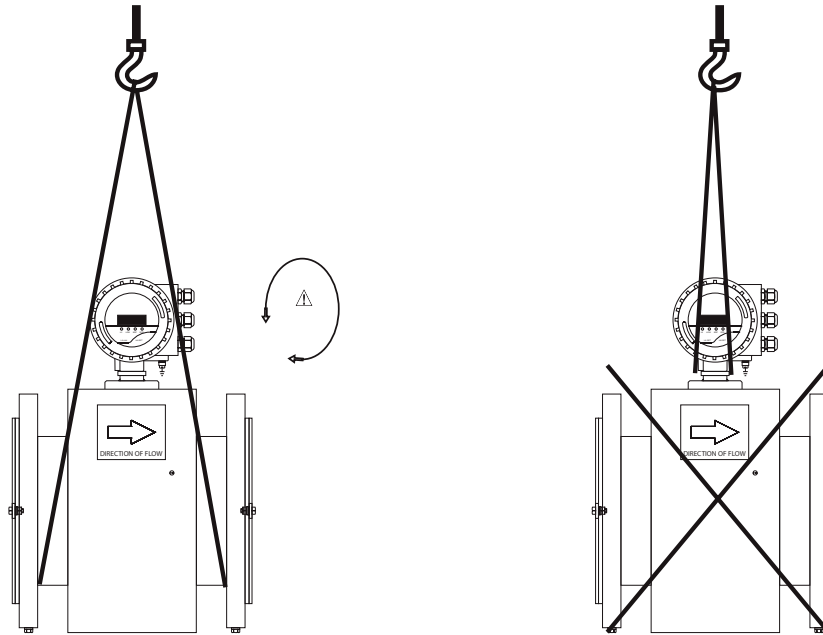

- B) For flow meter sizes equal to and greater than 6 inches (150mm) up to sizes 12 inches (300mm), use the eyebolts to lift, move and position the instrument.



Do not lift the instrument with a fork lift as this could cause the casing to buckle and damage the internal coils.

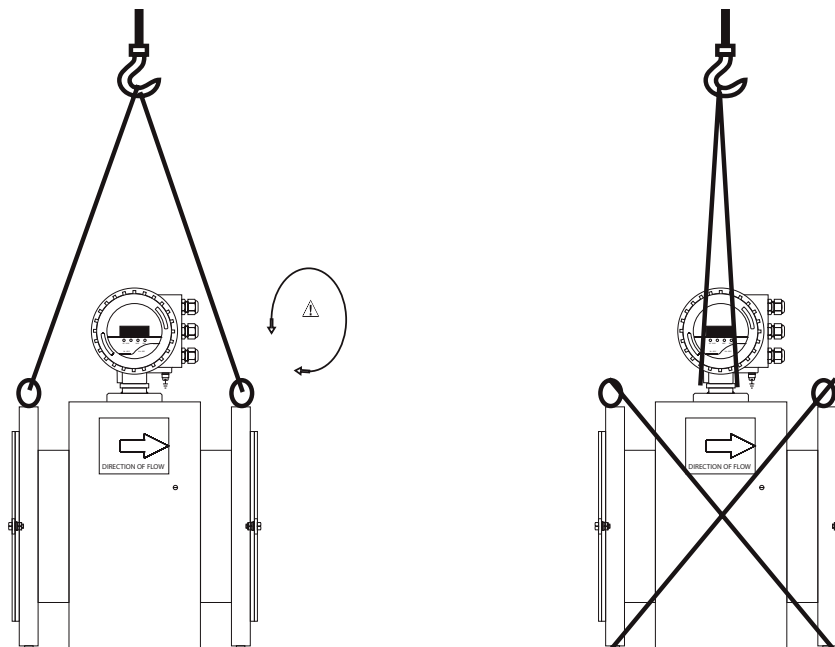

C) For flow meter sizes 10 inches and larger, use the lugs provided to lift, move and position the instrument.



Do not lift the instrument with a fork lift as this could cause the casing to buckle and damage the internal coils.

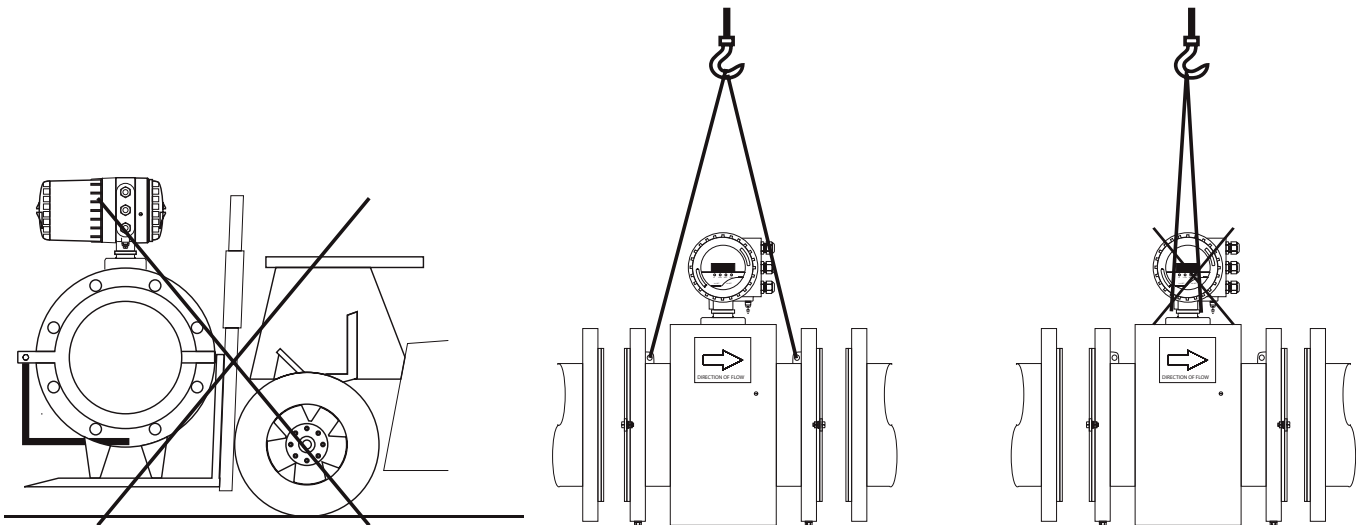

2.2 Storage

If storing the unit, care should be taken to avoid damage. The unit must be stored in a non-condensing atmosphere less than 100% relative humidity. Store between -50° F and 200° F.

3.0 MECHANICAL INSTALLATION

3.1 Guidelines

Installation Guidelines



- a) Only use the bolts and gaskets as described in the technical data of the operating manual
- b) Ensure the mains supply is switched off during installation.

Install the flow meter at a location, such that the pipe is always full at that location

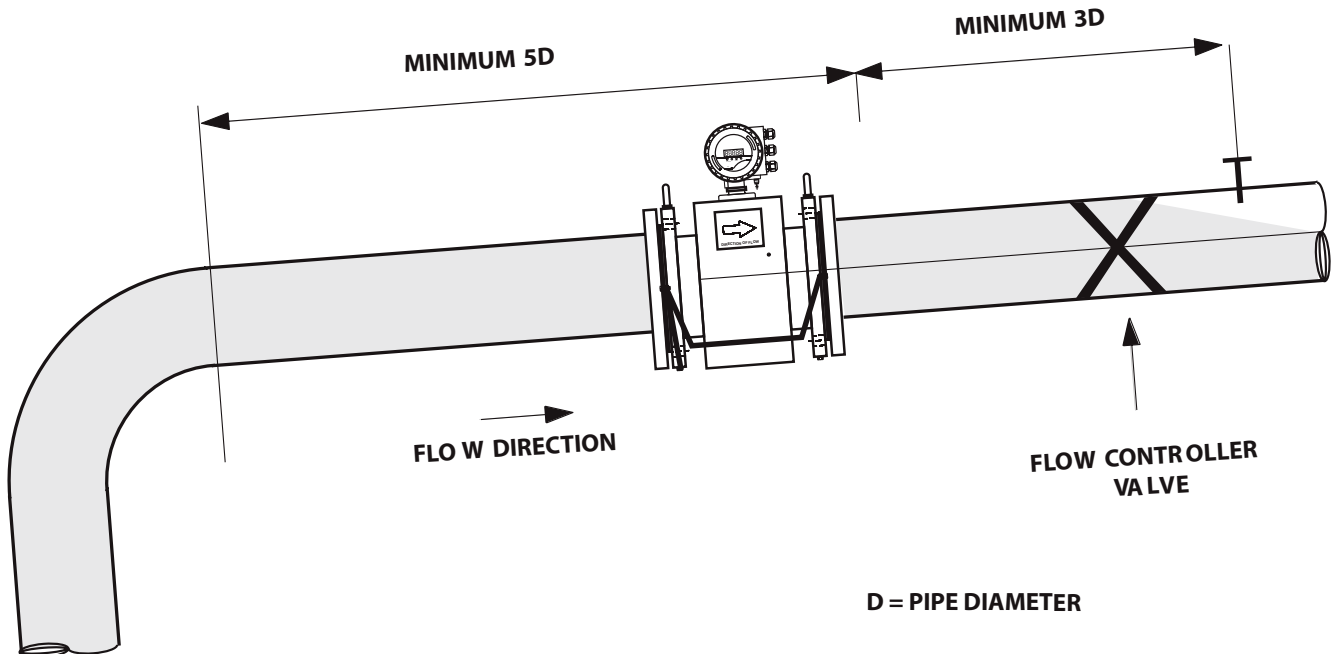

Install the flow meter vertically or at an incline with flow from down to up as this ensures that the pipe is always full.

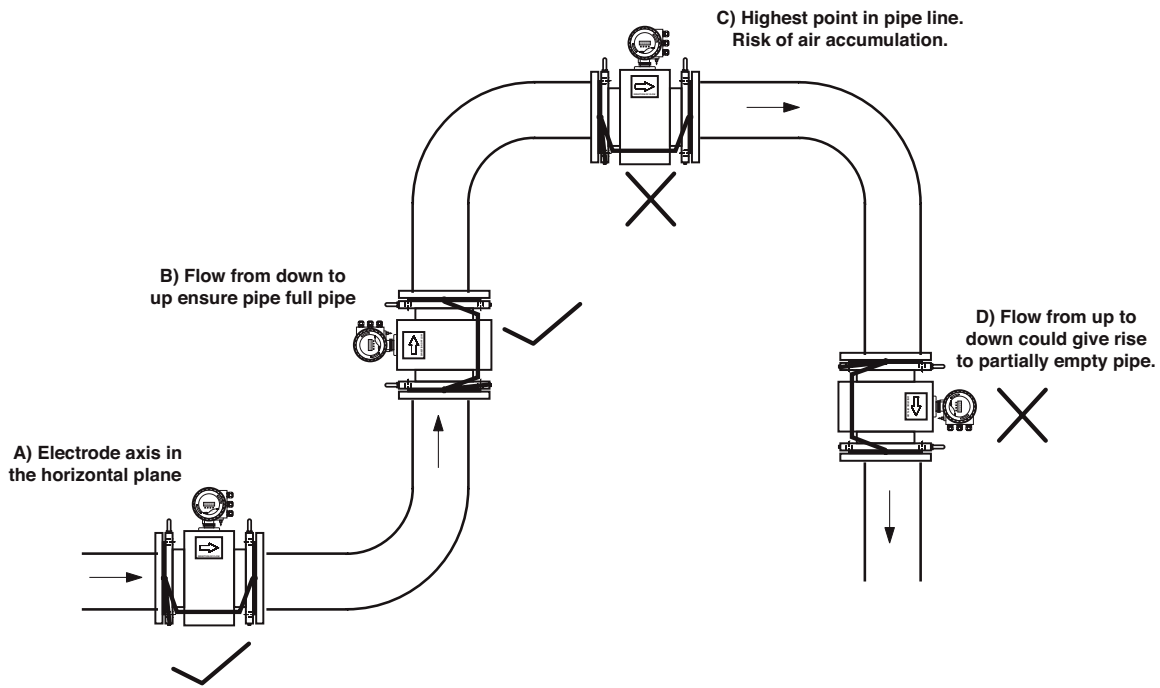

For horizontal installations, the electrode axis should always be in the horizontal plane. The flow meter should be installed such that the forward flow is always in the direction pointed by the arrow that is placed on the sensor body. Use of suitable gaskets can prevent leakage from near the flanges. However, gaskets should be perfectly aligned with the holes. Improperly aligned gaskets can cause considerable errors in the measurement.

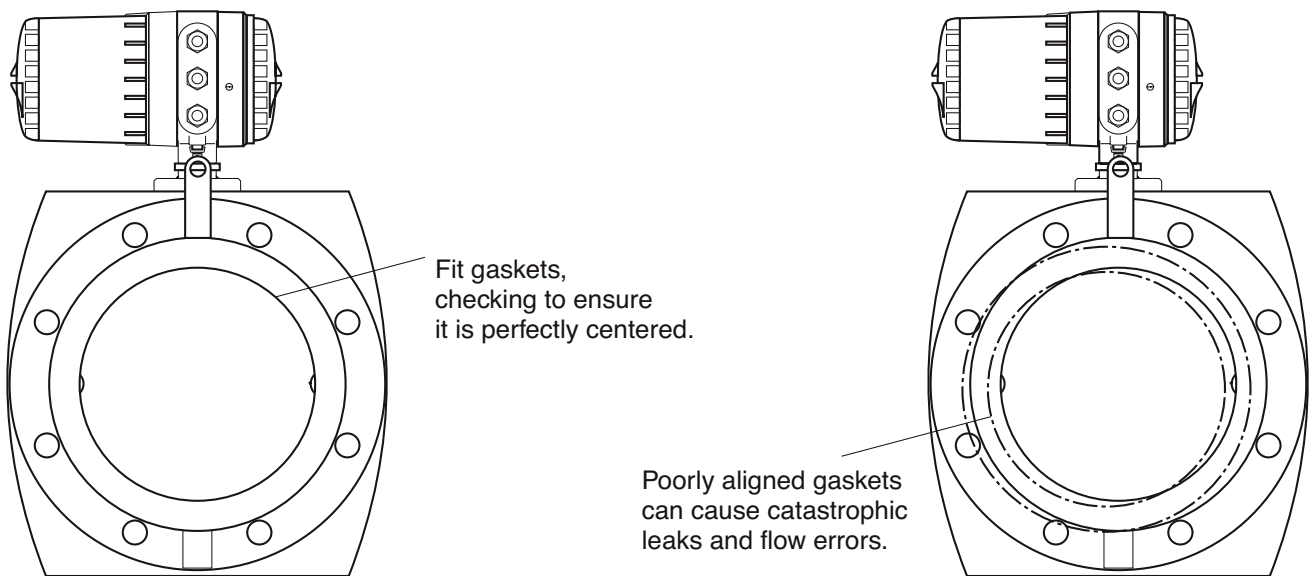

Do not install the flow meter on the intake side of the pump. This precaution is to avoid low pressure and the consequent risk of damage to the lining of the measuring tube.

If the application requires periodic removal of the flow meter for maintenance, then a bypass line should be installed.

If a valve lies on the pipeline, then the flow meter should be installed before the valve and not after it.

The orientation of the flow meter should be such that the Empty Pipe Detection Electrode is always on the topside of the pipe, otherwise the Empty Pipe Detection function may not work.

3.2 Mounting

Reducers and expanders should be used as shown when there is a difference in the size of the pipeline and the flow meter.

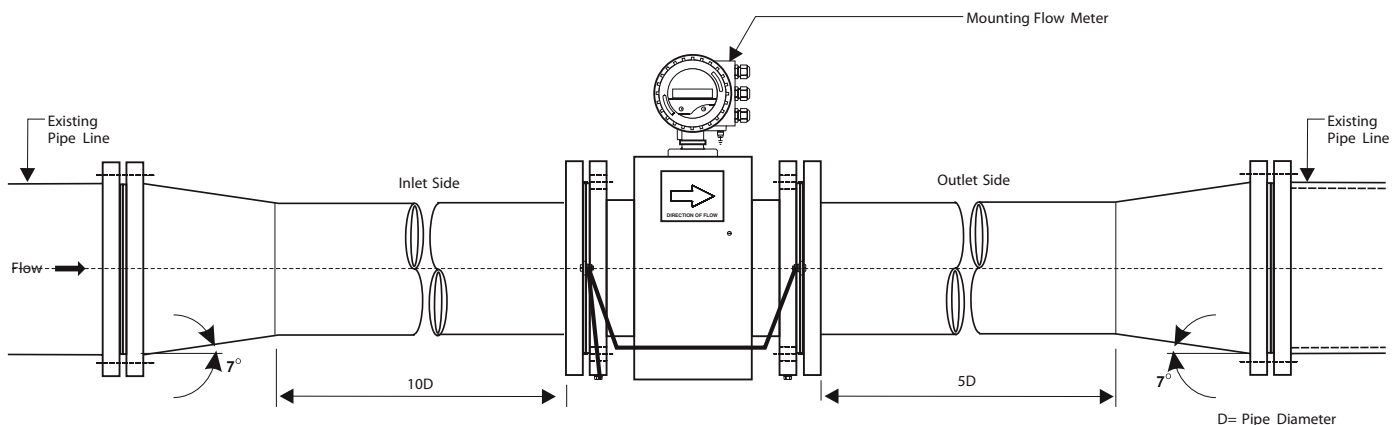

Flow meter screw tightening torque specifications

It is recommended to use gaskets made of either neoprene or PTFE.

Pipe Size (Inches)	Flange Pressure Rating	Max. Tightening Torque Ft/# PTFE/Hard Rubber	QTY - Bolt Size
0.5	150#	10	4 - 0.5 x 2.25
0.5	300#	10	4 - 0.5 x 2.25
1	150#	10	4 - 0.5 x 2.5
1	300#	15	4 - 0.625 x 3
1.5	150#	15	4 - 0.5 x 2.75
1.5	300#	25	4 - 0.75 x 3.5
2	150#	25	4 - 0.625 x 3
2	300#	35	8 - 0.625 X 3.2
3	150#	40	4 - 0.625 X 3.5
3	300#	60	8 - 0.75 x 4
4	150#	30	8 - 0.625 x 3.5
4	300#	50	8 - 0.75 x 4.25
6	150#	60	8 - 0.75 x 3.75
6	300#	75	12 - 0.75 x 4.75
8	150#	75	8 - 0.75 x 4
8	300#	105	12 - 0.875 x 5.25
10	150#	100	12 - 0.875 x 4.5
12	150#	130	12 - 0.875 x 4.5
14	150#	190	12 - 1 x 5
16	150#	180	16 - 1 x 5.25
18	150#	270	16 - 1.125 x 5.75
20	150#	250	20 - 1.125 x 6
24	150#	350	20 - 1.125 x 6.75

Bolt Tightening Sequence

Do not completely torque one side and then the other. Alternate tightening on up and down stream flanges.

Bolts should be tightened in the correct sequence and repeated several times to ensure that the specified bolt torques are achieved as shown. It must be noted on flange joints that some relaxation will be experienced and it should be ascertained that the bolt torques required to effect a seal at the appropriate pressure, as shown in the charts, are effective at the time of pressure testing. Bolt torques do not have to be restricted to those applicable to a specific test pressure and higher torques can be applied up to the maximum rated test pressure for the appropriate flange.

Notes: Use only undamaged rust free bolts.

Lubricate bolt threads and all mating surfaces of nuts and washers.

Tighten bolts in the sequence shown until torque is achieved.

Check, and if necessary, retighten bolts immediately before pressure testing.

For sizes having 12 bolts or more it is recommended that two joiners work simultaneously on diametrically opposite bolts. Each joiner tightens the first nut in the first quadrant, then the first nut in the second quadrant, returns to the second nut in the first quadrant and so on.

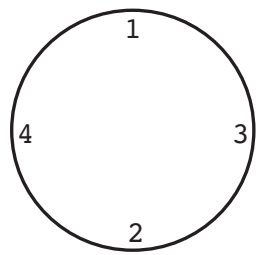

4 Bolts

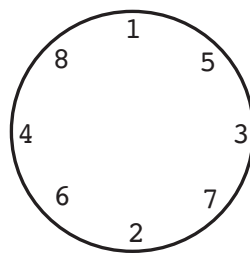

8 Bolts

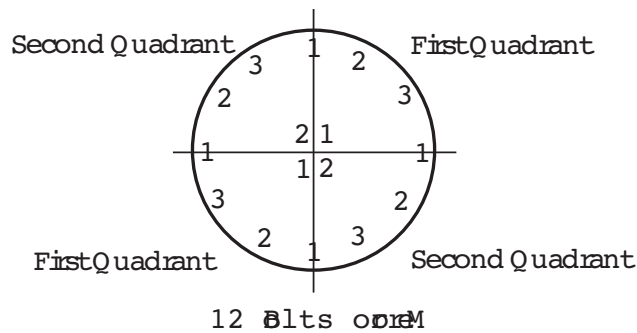

12 Bolts

4.0 ELECTRICAL WIRING

4.1 Guidelines

Connect the instruments as per the wiring diagrams given below.

All field wiring must have insulation suitable for at least 240 VAC.

The torque on the terminal clamping screws should be from 4.43# inches to 6.20# inches. Do not overtighten the screws.

Ensure a circuit breaker with a rating of 6A or a switch, marked as disconnect switch, is in close proximity to the instrument and within easy reach of the operator. The switch is required to disconnect the instrument from the mains supply.

The power should be connected through a 3 conductor mains cable suitable and approved for the country where the instrument is going to be used. The recommended conductor size for power supply and relay output is 14 gage with at least 250 VAC insulation.

Ensure that the instrument is connected to reliable ground. Use 14 gage conductor with at least 250 VAC insulation.

The recommended cable for 4-20 mA output and pulse output is the Belden 8760, shielded/twisted pair, 18 AWG (0.75 mm²) cable or equivalent.

Relay contact terminals are for use with equipment having no accessible live parts. Maximum allowable working voltage between adjacent relay contact shall be 230 V.

Relays are shown in De-energized condition. Maximum rating of relay is 2A at 230 V maximum for non-inductive load.

Fuse is rated as T 1.0A, 250 VAC (slow blow).

Care should be taken to ensure that no moisture or dust enters the housing.

Teflon Wire

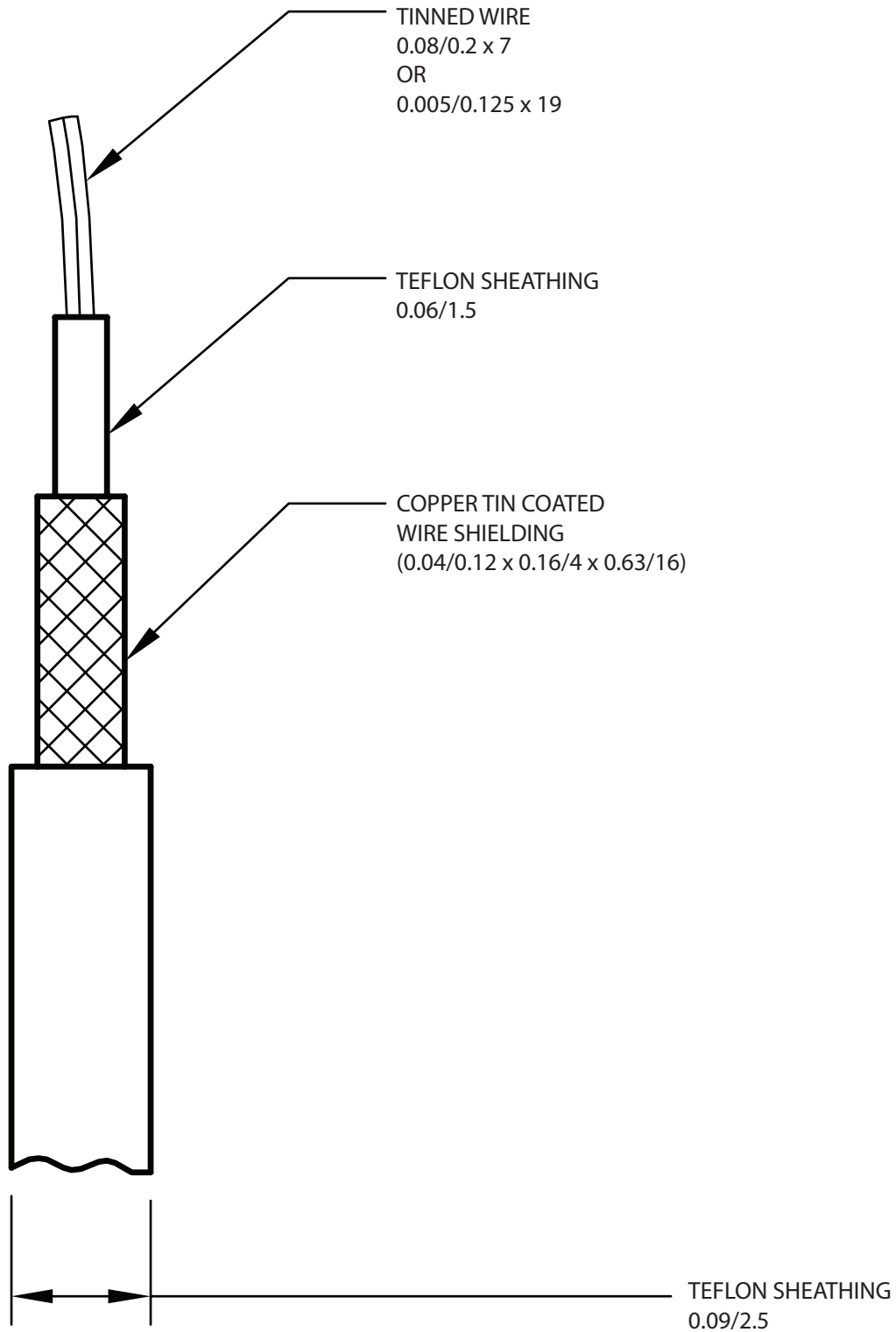

NOTES: All dimensions are in inches/mm.

**2 Core Shielded Cable
(For Separate Electronics)**

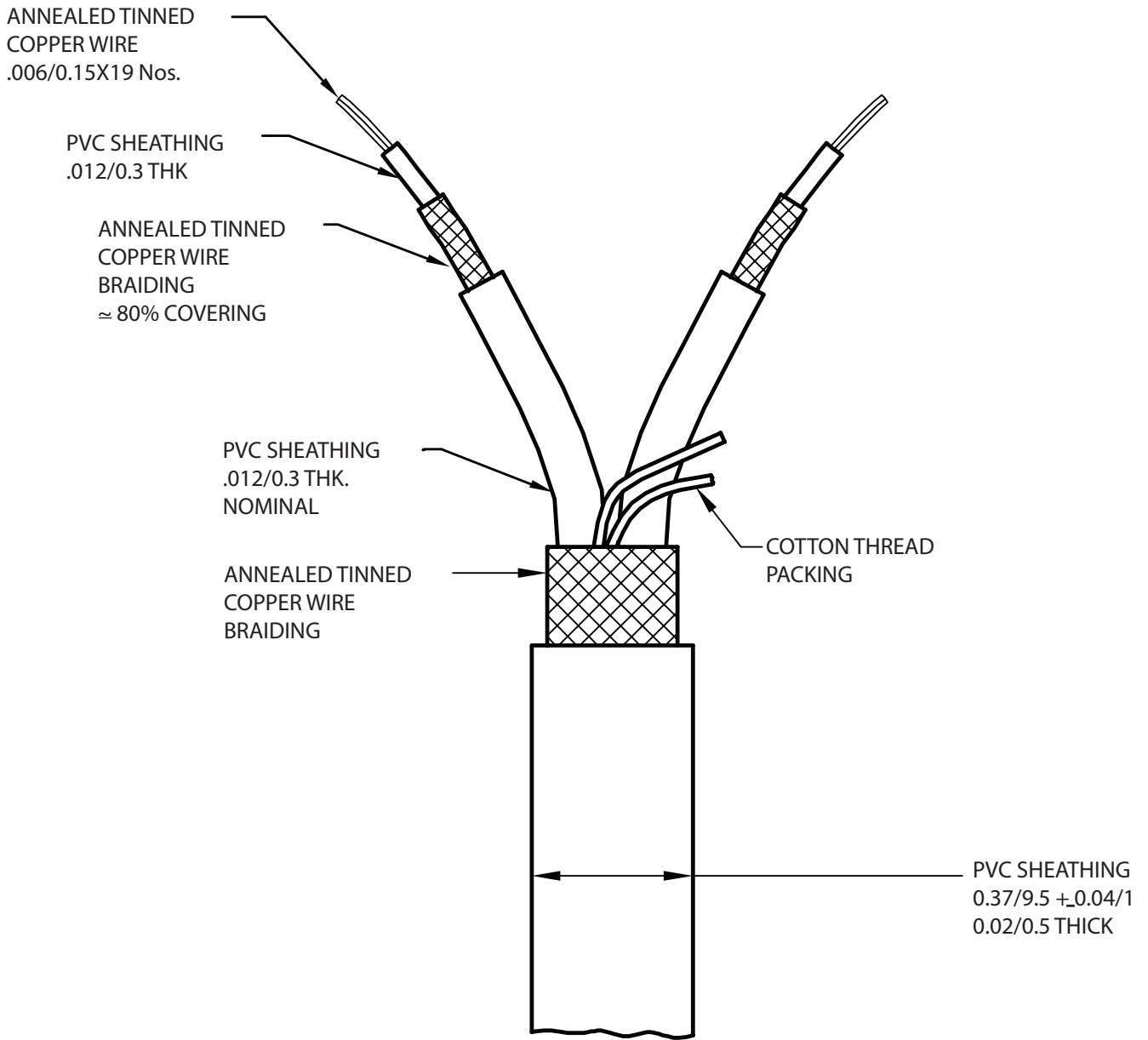

MAXIMUM RESISTANCE/KM: 58.7 Ohm

Note: All dimensions are in inches/mm.

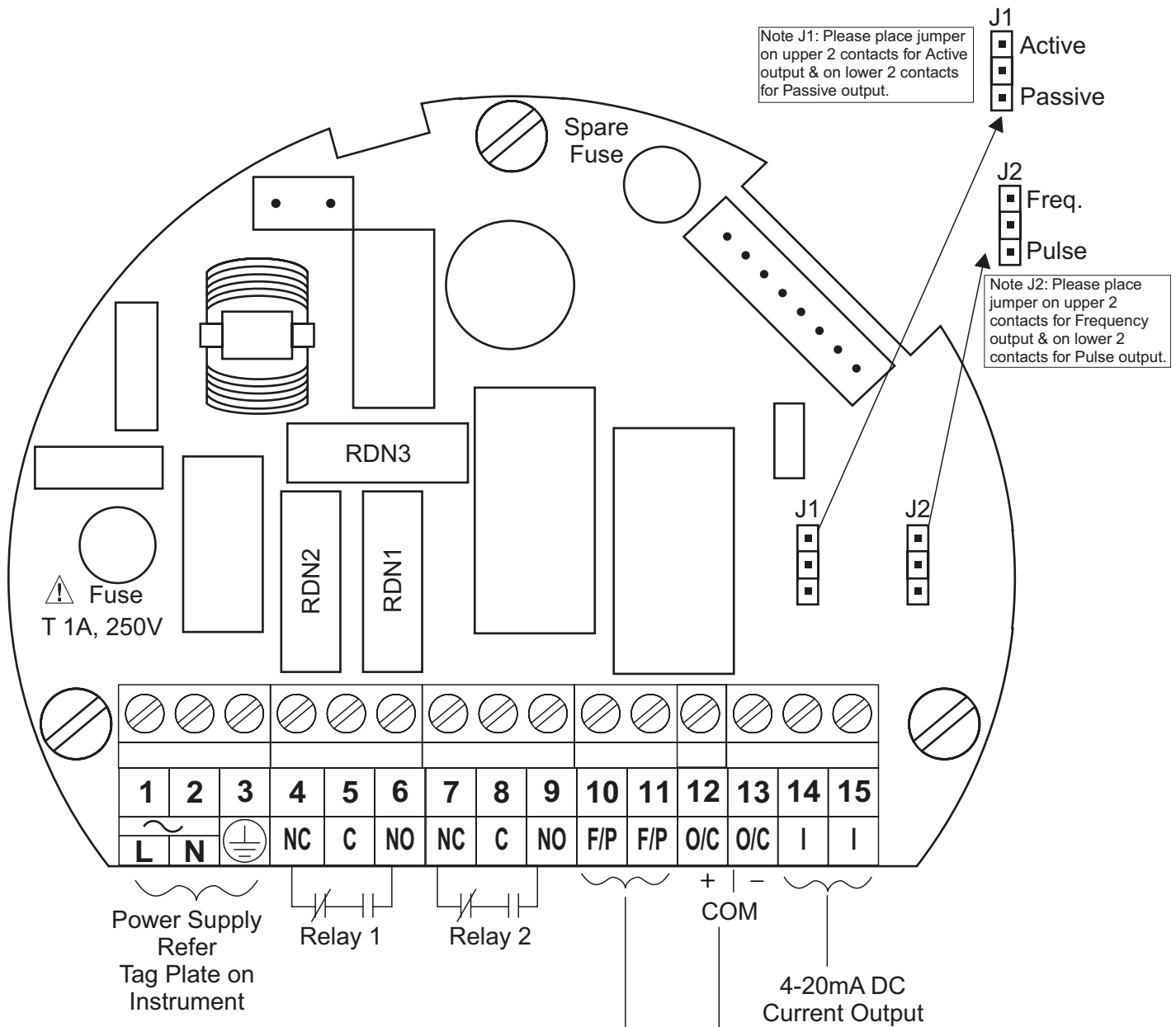

Wiring Diagram Legend

- 1 AC Hot L
- 2 AC Neutral
- 3 Ground
- 4 Relay 1 NC
- 5 Relay Common
- 6 Relay NO
- 7 Relay 2 NC
- 8 Relay Common
- 9 Relay NO
- 10 Frequency/Pulse
- 11 Frequency/Pulse
- 12 Open Collector +
- 13 Open Collector COM
- 14 4-20 mA +
- 15 4-20 mA -

Note: For use with 1030F place a 500 ohm resistor across A and $\frac{\perp}{\perp}$ of 1030. For a 3030 use a 1 ohm resistor across A and $\frac{\perp}{\perp}$. Jumper J1 is in active position and J2 is in frequency position in meter.

Open Collector (Passive) connection to Indicator

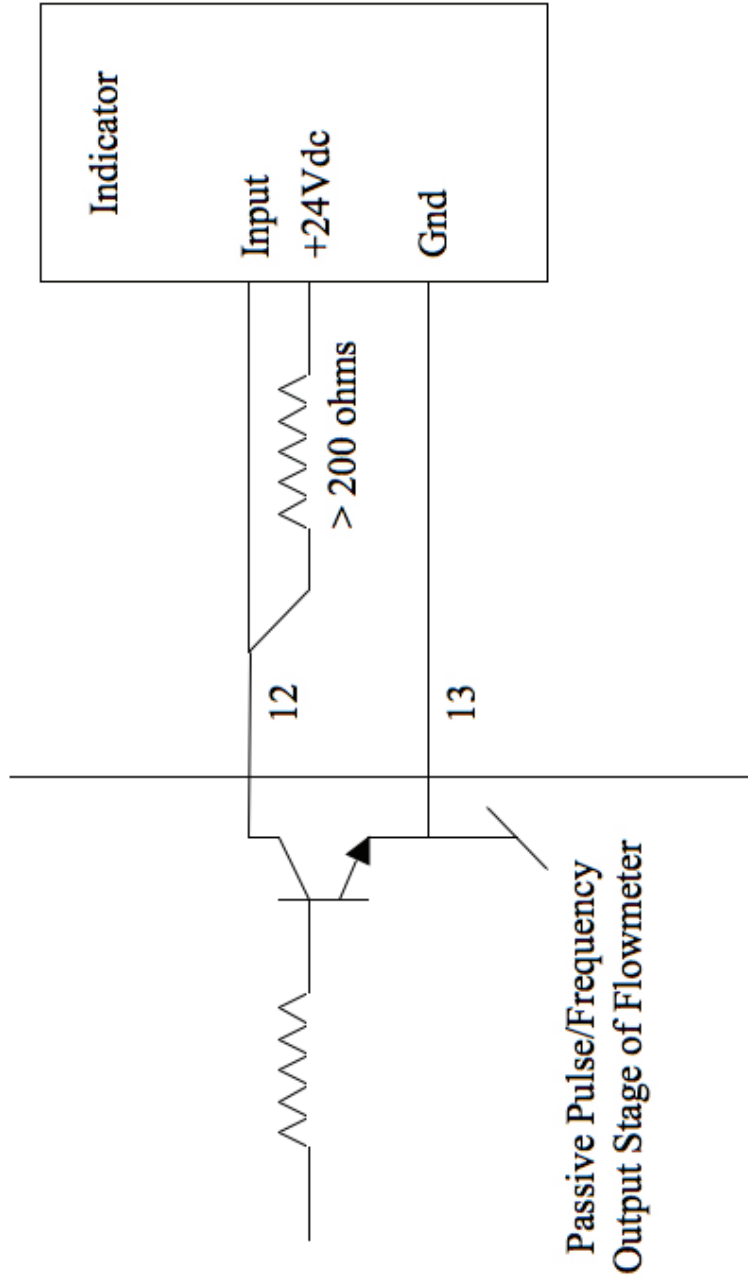

Passive Pulse/Frequency
Output Stage of Flowmeter

External Resistance (>200Ohm of suitable wattage) is required to be connected between Open Collector terminal and + terminal of power supply

Active Connection to Indicator

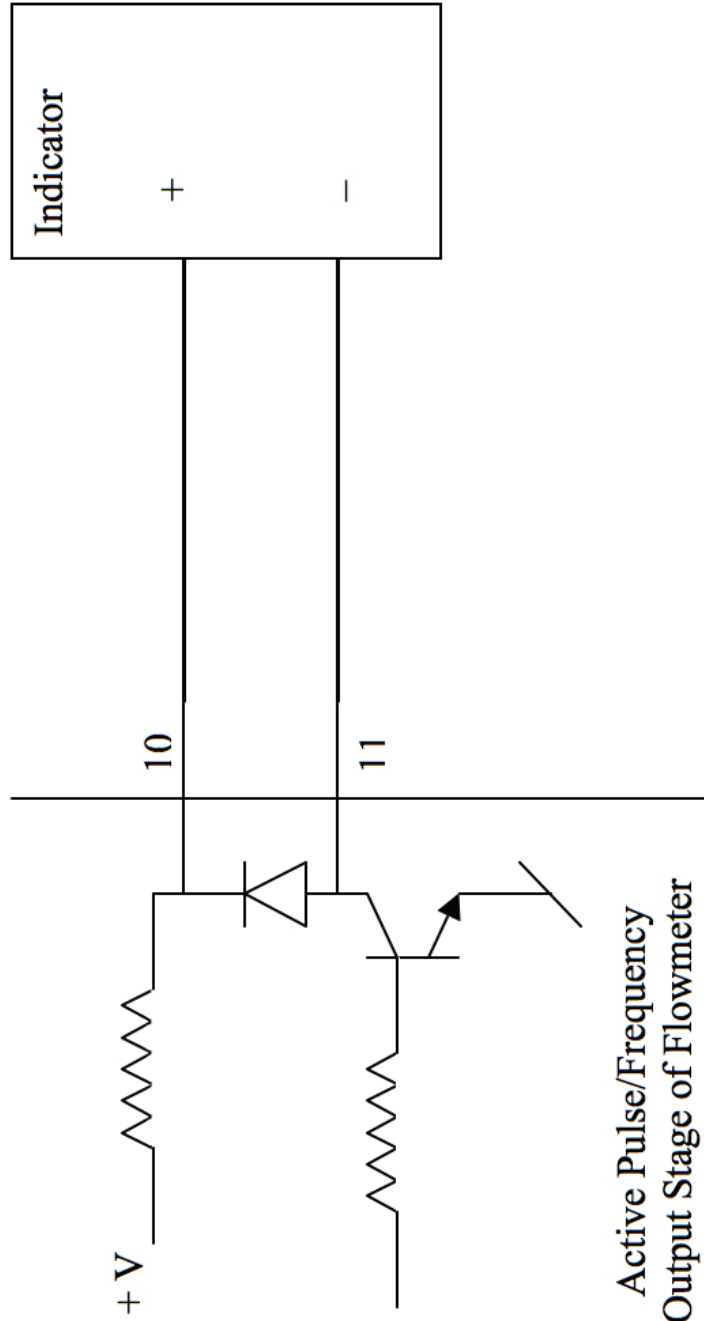

5.0 SET-UP & PROGRAMMING

Please note that these guidelines are for software version 7.00 or higher.

NOTE 1: After applying power to the flowmeters, wait 15 minutes before entering the Programming Mode.

PROGRAMMING PROCEDURE

Two magnetically operated Hall Effect switches are provided for Data Programming. These switches are located just below the 16x2 alphanumeric display. The left switch is the increment key and the right switch is the ENT key. Both of the keys can be operated without opening the cover by bringing a programming magnet near the switch.

ENTERING THE PROGRAMMING MODE

Data programming can be enabled by putting the programming magnet in front of the "E" ENT key for at least 1-2 seconds. The message will display:

Enter Password

Hit the ENT key. This message will display:

**Enter Password
00**

Default Passwords

LINE SIZE	PASSWORD
0.5"	15
1"	25
1.5"	40
2"	50
3"	80
4" and up	00

At this point, the cursor will be positioned to the most significant digit. A valid password entry will allow you to continue with the Programming Mode. An invalid password entry will display:

Access Denied

This will then cause an exit from the Programming Mode.

FLOW MEASUREMENT MODE SELECTION

After a valid password is entered, the programming will continue with the Flow Measurement Mode Selection. Bi-directional Mode or Uni-directional Mode can be selected. The default mode is Bi-directional Mode. You will see this message on the display:

**Flow Measurement
Set BDF/UDF Mode**

This is the default display. It will reset for any subsequent attempt for programming of parameters.

An enable to the ENT key will show the options in the programming. It will start with the default option of the Bi-directional Mode. This message will display:

**Flow Measurement
Bi-Directional**

An enable to the ENT key will accept this mode and programming will jump to the next parameter program. An enable to the increment key will continue with the second option. This message will display:

**Flow Measurement
Uni-Directional**

An enable to the ENT key will accept this mode and will show further options for selection. Other options include the Forward Mode and Reverse Mode. In Forward Mode of operation, the flowmeter will work only in a forward (positive) direction. Similarly, in the Reverse Mode of operation, the flowmeter will work only in a reverse (negative) direction. This message will display:

**Uni-Directional
Forward Mode**

An enable to the ENT key will accept this mode and programming will jump to the next parameter. An enable to the increment key will show the second option, Reverse Mode. This message will display:

**Uni-Directional
Reverse Mode**

An enable to the ENT key will accept this mode and programming will jump to the next parameter, which is Display Mode Programming. An enable to the increment key will continue with the loop for Uni-Directional Forward Mode.

DISPLAY MODE PROGRAMMING

Programming will continue with Display Mode Programming. The default display is:

**Display
Flow Rate + Tot**

This Display Mode is the default and will reset for any subsequent attempt for programming of parameters.

An enable to the ENT key will accept this mode and programming will jump to the next parameter. An enable to the increment key will set the second option of the Display Mode. This message will display:

**Display
Flow Rate**

An enable to the ENT key will accept this mode and programming will jump to the next parameter. An enable to the increment key will continue this loop.

FLOW RATE PROGRAMMING

After the Display Mode Programming, the next parameter in the programming queue is Flow Rate Programming. This message will display:

Flow Rate

An enable to the increment key will cause the programming to jump to the next parameter. An enable to the ENT key will activate the Unit for Program Mode and display the following message:

**Unit for Program
CuM/hr**

The Unit of Program in CuM/hr is the default parameter. It will reset to this for any subsequent attempt for programming of parameters.

An enable to the ENT key will accept this mode and programming will jump to the next parameter. An enable to the increment key will set mode to the other option of Unit for Program and the display will show the following message:

**Unit for Program
GPM**

An enable to the ENT key will accept this unit for programming and programming will jump to the next parameter. An enable to the increment key will continue this loop.

Flow Rate, Totalizer Unit, Pulse Value, Hi Flow Alarm, Lo Flow Alarm, and Creep Suppression parameters will be set in units according to the selection made during the Unit for Program Mode (CuM/hr or GPM).

An enable to the ENT key will enable Flow Rate Programming and the display will now show the previous value set. The cursor will position itself to the most significant digit of the displayed value.

When Unit for Program is set to CuM/hr, the following message will display:

**Flow Rate
70.00 CuM/hr**

When Unit for Program is set to GPM, the following message will display:

**Flow Rate
308.0 GPM**

Enabling the increment key will increment the digit to which the cursor is positioned, while an enable to the ENT key will accept the data and the cursor will move forward to the next position. When required, use the ENT key to enter the value of the rate of flow and move on to the next programming parameter, Display Units.

DISPLAY UNITS

Display Units for flow rate will be set in units according to the selection made during the Unit for Programming Mode (CuM/hr or GPM).

If the Unit of Program is set to CuM/hr, then display units can be set as CuM/hr, LPM, and LPS. The default value for Display Units of flow rate is CuM/hr. An enable to the ENT key will accept the data and programming will jump to the next parameter in the programming queue.

**Display Unit
CuM/hr**

The other options for Display Units are LPM and LPS. This option can be selected by enabling the increment key and accepted by an enable to the ENT key.

**Display Unit
LPM**

The option can be selected by enabling the increment key and accepted by an enable to the ENT key.

**Display Unit
LPS**

If Unit of Program is set to GPM, then Display Units can be set as GPM, GPS, GPH, CFM, CFS, or CFH. The default value for Display Units of flow rate is GPM. An enable to the ENT key will accept the data and programming will jump to the next parameter in the programming queue.

**Display Unit
GPM**

Another option can be selected by enabling the increment key and accepted by an enable to the ENT key.

**Display Unit
GPS**

Another option can be selected by enabling the increment key and accepted by an enable to the ENT key.

**Display Unit
GPH**

Another option can be selected by enabling the increment key and accepted by an enable to the ENT key.

**Display Unit
CFM**

Another option can be selected by enabling the increment key and accepted by an enable to the ENT key.

**Display Unit
CFS**

Another option can be selected by enabling the increment key and accepted by an enable to the ENT key.

**Display Unit
CFH**

TOTALIZER UNITS

Next in the Display Units Mode is the Totalizer Units. This is the display of units for the built-in flow integrator. The Unit for Display is CuM or Gals, which has to be accepted by enabling the ENT or increment keys.

If Unit for Program is CuM/hr, the following message will display:

**Totalizer Units
CuM**

No other option for Totalizer Units can be set for the Units for Program CuM/hr option.

If Units for Program is GPM, the following message will display:

**Totalizer Units
Gals**

No other option for Totalizer Units can be set for the Units for Program GPM option.

If the Display Mode programming mode is selected, programming will omit the Totalizer Units programming parameter.

**Display
Flow Rate**

PULSE VALUE

The next programming parameter is the Pulse Value. An enable to the ENT key to Pulse Value will show 0.001 CuM/Imp or 001.0 Gal/Imp with the cursor positioned next to it. An enable to the increment key will increment the data by one, while an enable to the ENT key will accept the data and exit the Pulse Value subroutine.

A Pulse Value of 0.001 to 9.999 CuM/Imp or 000.1 to 999.9 Gal/Imp can be set in this subroutine.

If Units for Program is CuM/hr, the following message will display:

**Pulse Value
0.001 CuM/Imp**

0.001 CuM/Imp is the default value for Pulse Value for the CuM/hr option of Units for Program. This means it will reset for any subsequent attempt for programming of parameters.

If Units for Program is GPM, the following message will display:

**Pulse Value
001.0 Gal/Imp**

001.0 Gal/Imp is the default value for Pulse Value for the GPM option of Units for Program. This means it will reset for any subsequent attempt for programming of parameters.

RESET TOTALIZER

The next programming parameter is the Reset Totalizer. Any of the Forward, Reverse, or Both Totalizers can be reset to all zero value in this menu of programming. The following message will display:

**Reset Totalizers
?**

NOTE 2: An increase at this point will bypass the Reset Totalizer function and move to the Set Pulse On Time screen.

An enable to the ENT key will ask for resetting of the Forward (positive) Totalizer, and an enable to the increment key will come out of this menu and jump to the next parameter in the programming queue, Set Pulse On Time.

**Reset Forward (+)
Totalizer ?**

An enable to the ENT key for this option will confirm the resetting of the Forward Totalizer. An enable to the increment key will ask for resetting of the Reverse (negative) Totalizer. An enable to the ENT will display the following message:

**Are you sure?
Reset Totalizer?**

An enable to the ENT key will reset the Forward Totalizer and will display the message below. An enable to the increment key will start the Reset Reverse Totalizer subroutine.

**Resetting ...
Totalizer ...**

After this subroutine, the program will jump to the next parameter, Set Pulse On Time.

The subsequent display which will follow for resetting of Reverse Totalizer will be:

**Reset Reverse (-)
Totalizer ?**

An enable to the ENT key for this option will confirm the resetting of the Reverse Totalizer, and an enable to the increment key will jump to the Reset Both Totalizers submenu. An enable to the ENT key will display the following message:

**Are you sure?
Reset Totalizer?**

An enable to the ENT key will reset the Reverse Totalizer and will show the following display and an enable to the increment key will jump to the Reset Both Totalizers submenu.

**Resetting ...
Totalizer ...**

After this submenu, the program will jump to the next parameter, Set Pulse On Time.

The subsequent display which will follow for resetting of Both Totalizers will be:

**Reset Both (+,-)
Totalizers ?**

An enable to the ENT key for this option will confirm the resetting of Both Totalizers, and an enable to the increment key will jump to the Reset Totalizers subroutine. An enable to the ENT key will display the following message:

**Are you sure?
Reset Totalizer?**

An enable to the ENT key will reset both the Forward and Reverse Totalizers and it will show the following display. An enable to the increment key will jump to the Reset Totalizers submenu.

**Resetting ...
Totalizer ...**

After this submenu, the program will jump to the next parameter, Set Pulse On Time.

SET PULSE ON TIME

The next programming parameter is Set Pulse On Time. The following message will display:

**Set
Pulse On Time?**

When it is required to Set Pulse On Time, enable the ENT key on this display. An enable to the increment key to Set Pulse On Time will continue with the next programming parameter.

An enable to the ENT key will display the following message:

**Pulse On Time
20 mSec**

A Pulse On Time of 1 mSec to 99 mSec can be set in this subroutine.

SET ALARMS

The next programming parameter is Set Alarms. An enable to the ENT key will continue to this subroutine, while an enable to the increment key will jump to the next programming parameter. High and low flow alarms can be set in this programming menu.

A HI Flow Alarm can be set up to 110% of the maximum flow rate for a given NB size instrument.

A LO Flow Alarm can be programmed throughout the range provided. A HI Flow Alarm value should be greater than the LO Flow Alarm value and the LO Flow Alarm value should be greater than the Creep Suppression Level.

Set Alarms?

An enable to the ENT key will enter into the programming menu. A HI Flow Alarm and LO Flow Alarm can be set in the sequence in this parameter programming.

If Unit for Program is CuM/hr, the following message will display:

**Enter HI Alarm
70.00 CuM/hr**

If Unit for Program is GPM, the following message will display:

**Enter HI Alarm
308.0 GPM**

An enable to the increment key will increment the digits by one, using the cursor. An enable to the ENT key will accept the data and position the cursor to the next digit.

When the entry for the HI Alarm is complete, an enable to the ENT key will accept the data and will jump to the next loop. An enable to the increment key will display the previous value of the LO Alarm.

If Unit for Program is CuM/hr, the following message will display:

**Enter LO Alarm
10.00 CuM/hr**

If Unit for Program is GPM, the following message will display:

**Enter LO Alarm
044.0 GPM**

An enable to the increment key will increment the digits by one, using the cursor. An enable to the ENT key will accept the data and position the cursor to the next digit.

When the entry for the LO Alarm is complete, an enable to the ENT key will accept the data and will jump to the next programming parameter.

RELAY SELECTION

There are two configurable relay outputs. Relay 1 and Relay 2 can be configured using this parameter program. Relay 1 can be configured as a HI Flow Alarm OR as a Bi-directional Flow Detection. Relay 2 can be configured as a LO Flow Alarm OR as a Empty Pipe Detection.

An enable to the ENT key will display the following message:

**Relay Selection
?**

An enable to the ENT key will continue with the configuration of the relay and will show the following display:

**Relay Selection
Relay 1 = HA Flow**

Relay 1 = HA Flow is the default parameter. This is the reset value for any subsequent attempt for programming of parameters.

An enable to the ENT key will accept the selection, or an enable to the increment key will display the following message:

**Relay Selection
Relay 1 = BDF**

An enable to the ENT key will accept the selection and will jump to the selection menu of Relay 2, or an enable to the increment key will continue with the relay selection subroutine for Relay 1.

Relay 2 can be configured as follows:

**Relay Selection
Relay 2 = LA Flow**

Relay 2 = LA Flow is the default parameter. This is the reset value for any subsequent attempt for programming of parameters.

An enable of the ENT key will accept this configuration, while an enable of the increment key will show the following display:

**Relay Selection
Relay 2 = EPD**

An enable to the ENT key will accept the selection and will jump to the next programming parameter, Creep Suppression Programming, or an enable to the increment key will continue with the relay selection loop for Relay 2.

An increment to Relay Selection will continue on to the next programming parameter.

CREEP SUPPRESSION PROGRAMMING

Creep Suppression Programming follows the Relay Selection Programming. An enable of the ENT key will continue with this subroutine. Creep Suppression or CS Level is the flow limit below which the current output is forced to live datum (ie, 4 mA).

**Creep Suppression
?**

If Unit for Program is CuM/hr, the following message displays:

**Enter CS Level
0.9 CuM/hr**

If Unit for Program is GPM, the following message displays:

**Enter CS Level
04.35 GPM**

An enable to the ENT key will accept the data and an enable to the increment key will advance it by one. Creep Suppression Level up to 9.9 CuM/hr or 43.56 GPM can be programmed provided CS Level is less than LO Flow Alarm value.

Detection of Creep Suppression Level will drive the current output to 4 mA. This will cause the Totalizer to stop and display will show a zero value for Flow Rate.

DISPLAY DAMP

After Creep Suppression Programming is complete, the next parameter in the queue is Display Damp. An enable to the ENT key will continue with this subroutine.

Display Damp?

**Damping Factor
1**

Display Damp factor can be set from 1 to 9. An enable to the ENT key will accept the data and will move further to Exit the programming mode.

EXIT

After the programming of parameters is complete, the program will ask to exit. The following message will be displayed:

**EXIT?
ENT To Exit**

An enable to the ENT key will exit the programming. The following message may appear for approximately 40 seconds while the program is exiting.

**Please Wait ...
Copying Data ...**

CHANGE PASSWORD

An enable to ENT key when EXIT is displayed will exit from the programming mode, whereas an enable to the increment key will ask for a change of password.

**Change Password
?**

An enable to the ENT key will continue with this subroutine, while an enable to the increment key will jump to the first programming parameter (Display Mode Programming).

An enable to the ENT key will make an entry and the following message will be displayed:

New Password?

An enable to the ENT key will show 00 value to password, which can be set to a desired value. After the new password entry is complete, the following message will display:

Done?

Display will show Instantaneous Flow Rate and Flow Totalizer. An enable to the increment key after Done will continue with the new password subroutine.

The default password (up to 80 NB) is NB size of that instrument. For instruments above 80 NB size, the default password is 00.

START/STOP OF FLOW TOTALIZER

Flow Totalizer can be stopped with a continuous enable to the increment key when the display is showing Instantaneous Flow Rate and Flow Totalizer value. The Flow Totalizer will remain stopped until the increment key is activated. The Flow Totalizer will restart after updating the value from the Flow Integrator, once the increment key is released.

6.0 Maintenance



Never attempt to loosen the process connections or instrument housing while the process/pipe/sensor is under pressure.

The electronic part of the instrument needs no maintenance, as there are no moving parts.

If the material is sticky in nature, it is advisable to periodically clean the electrodes of the instrument.

Ensure that the cable glands and the housing lid are sealed to prevent the ingress of dust and moisture.

Replacing The Fuse



Before relacing the fuse, ensure that the mains supply is switched off.

The procedure for replacing the fuse:

If Fuse Holder is of type TR5

1. Unscrew the terminal cover of the instrument.
2. Identify fuse type Tr5 on terminal board.
3. Remove all connections. Unscrew the terminal PCB.
4. Pull out blown fuse.
5. Insert new fuse into base TR51A, 230 VAC.
6. Replace terminal PCB. Screw back into place ensuring it is tight.
7. Make all the connections.
8. Tighten the terminal cover.
9. Switch ON the instrument.

7.0 Diagnostic Messages

DISPLAY	DESCRIPTION
Set F/R > Max Lt Reset Flow Rate	For a given NB size whenever programmed flow rate is greater than the maximum limit of flow rate, display will prompt the programmer and programming will jump to Flow Rate Programming
Too High Flow	Whenever input flow rate is greater than the 110% of maximum limit this message will appear on the display and the display will toggle with this message and the instantaneous flow rate
XXX.X CuM/hr XXXXXXXX CuM H	This message will appear on the display whenever the HI Alarm Level is reached
XXX.X CuM/hr XXXXXXXX CuM L	This message will appear on the display whenever the LO Alarm Level is reached
000.0 CuM/hr XXXXXXXX CuM LC	This message will appear on the display whenever the CS Level is reached
H < L Reset HI Alarm	Whenever set HI Alarm is less than LO Alarm while programming HI Alarm, display will prompt the programmer with this message and programming will jump to HI Alarm programming
H < L Reset LO Alarm	Whenever set LO Alarm is greater than HI Alarm while programming LO Alarm, display will prompt the programmer with this message and programming will jump to LO Alarm programming
CS > L Reset LO Alarm	Whenever set LO Alarm is less than CS Level while programming LO Alarm, display will prompt the programmer with this message and programming will jump to Low Alarm programming
CS > L Reset CS Level	Whenever set LO Alarm is less than CS Level while programming Creep Suppression, display will prompt the programmer with this message and programming will jump to Creep Suppression programming
+XXX.X CuM/hr +XXXXXXXX CuM	Flow rate in forward direction and Forward Totalizer display
-XXX.X CuM/hr -XXXXXXXX CuM	Flow rate in reverse direction and Reverse Totalizer display
+XXX.X CuM/hr +XXXXXXXX CuM LE	This message will appear on display when empty pipe/half-filled pipe is detected
Forward Mode Selected	This message will appear on display when Uni-directional Forward Mode is selected and flow in pipe line is finite and in reverse direction.
Reverse Mode Selected	This message will appear on display when Uni-directional Reverse Mode is selected and flow in pipe line is finite and in forward direction.

NOTE:

1. The display unit for flow rate will be according to set unit.
2. The Totalizer unit will be in CuM or Gal.

8.0 TROUBLESHOOTING

Sr. No.	Problem	Possible Cause	Corrective Action
1	Instrument dead	<ol style="list-style-type: none"> 1. Power off 2. Loose wiring 3. Fuse blown 4. Mains not available 	<ol style="list-style-type: none"> 1. Switch on power 2. Check wiring 3. Replace fuse 4. Check mains supply
2	Current output not available	<ol style="list-style-type: none"> 1. Wires may be open 2. Power supply card or amp may be faulty 	<ol style="list-style-type: none"> 1. Check wiring 2. Replace card Consult Factory
3	LED display blank	<ol style="list-style-type: none"> 1. Fuse may be blown 2. Power supply card may be faulty 	<ol style="list-style-type: none"> 1. Check and replace fuse 2. Replace Card Consult Factory
4	Alarm signal at wrong flow rate value	Setpoints for alarm may be incorrect	Check the programmed values of the alarm setpoints
5	Display black near edges	Very high temperature generated inside enclosure	Contact factory
6	Poor readability of display	<ol style="list-style-type: none"> 1. Viewing angle 2. Environmental brightness 	<ol style="list-style-type: none"> 1. Adjust viewing angle 2. Adjust contrast by trim pot provided just below display
7	Relay output not available	Incorrect or loose wiring	Check wiring



venture

MEASUREMENT

**150 Venture Boulevard
Spartanburg, SC 29306**

Phone: (864) 574-8060, Fax: (864) 574-8063

Customer Care: (800) 778-9242

Internet: <http://www.niagarameters.com>

email: sales@niagarameters.com