

EX80-Series

Seametrics

ELECTROMAGNETIC FLOW SENSOR INSTRUCTIONS



EX81
EX82
EX83

EX80-SERIES ELECTROMAGNETIC FLOW SENSOR INSTRUCTIONS

TABLE OF CONTENTS

General Information

Features, Specifications Page 1

Installation

Distorted Flows, Fitting Installation, Chemical Injection or Fertigation, Meter Installation,
Positioning the Meter Page 2

Straight Pipe Recommendations Page 3

Full Pipe Recommendations Page 4

Electrical Connections

General Electrical Guidelines, Power, Forward Flow Output, Reverse Flow Output,
Grounding Guidelines, Grounding Diagram..... Page 5

Connections Diagrams

Counter or PLC, A055 4-20 mA Output, FT520 Controller Page 6

FT420 Display and Proportional Feed, FT420 & 4-20 mA Output,
Dual FT420 Displays (example of bidirectional connection)..... Page 7

DL76, FT420/DL76 Page 8

Operation & Maintenance

Zero Adjustment, Minimum Flow, Flow Rate Table, Presence of Flow Indication,
Filtering, Electrode Coating, Calibration (“K-Factor”), K-Factor Chart Page 9

Caution & Troubleshooting

Problems, Probable Causes Back

TABLES AND DIAGRAMS

Features Page 1

Specifications Page 1

Distorted Flows, Positioning the Meter..... Page 2

Straight Pipe Recommendations Page 3

Full Pipe Recommendations Page 4

Grounding Diagram..... Page 5

Counter or PLC, A055 4-20 mA Output, FT520 Controller Page 6

FT420 Display and Proportional Feed, FT420 & 4-20 mA Output,
Dual FT420 Displays (example of bidirectional connections) Page 7

DL76, FT420/DL76 Page 8

Flow Rate Table, K-Factor Chart Page 9

Troubleshooting Back

GENERAL INFORMATION

EX80-Series insertion electromagnetic flowmeters are designed for use with conductive liquids in 1 to 12" pipe. A choice of materials (stainless steel, brass, and PVC) allows the meter to adapt to a range of temperature, pressure, and corrosive environments.

The EX80 is highly suitable for difficult applications with changing viscosities and pulsating flows, such as air-driven diaphragm pumps. With no moving parts, these meters can be used in "dirty" applications where debris would foul a mechanical meter. Like all magmeters, when used in chemical injection applications, these meters should be installed upstream of the chemical line (or far enough downstream to allow complete mixing of fluids before the meter).

Designed for modularity and versatility, the EX80-Series has a current-sinking pulse output that can be combined with the appropriate transmitter or indicator for the application. For

analog output and display of rate and total, an FT420 can be used. Blind analog output is provided by the AO55. The PD10 can be used to divide the pulse for pacing chemical metering pumps and the DL76 (data logger) is also compatible. Modules can be wall- or meter- mounted. If the EX80 meter is used with a programmable controller, the output signal can be fed direct, with no other conditioning required.

EX80-Series fixed depth insertion meters require special fittings. Factory installation in the fitting ensures correct depth placement in the pipe. The EX80-Series meter can be ordered in a full power model when a source of electricity is available, or in a low power model that can run on an external battery with solar panel.

Reverse flow output and immersibility are optional.

FEATURES

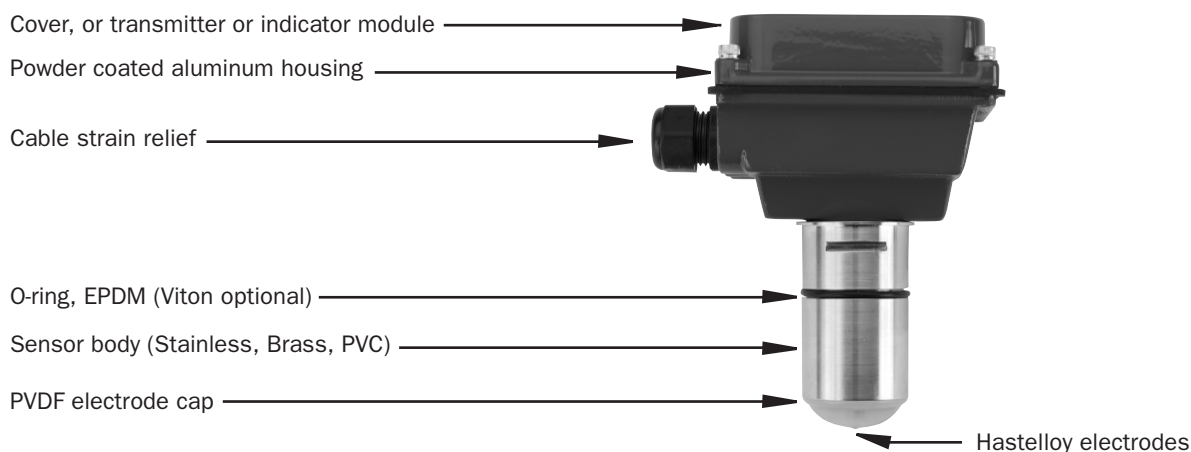

SPECIFICATIONS*

Pipe Size		1" to 12"
Materials	Mechanical	316 SS/Brass/PVC
	Electrodes	Hastelloy
	Housing	Cast powder-coated aluminum
	Electrode Cap	PVDF (Kynar)
	O-Ring	EPDM standard (Viton optional)
Power	Full Power	12 - 25 Vdc, 250 mA
	Low Power	12 - 25 Vdc, 40 mA average with 250 mA peaks
Flow Rate		0.28 - 20 ft/sec (0.08 - 6.09 m/sec)
Temperature	Ambient Temp	0° to 160° F (-17° to 72° C)
	Fluid Temp : Brass/SS	32° to 200° F (0° to 93° C)
	Fluid Temp: PVC	32° to 130° F (0° to 55° C) @ 0 psi
Pressure	Brass/SS	200 psi (13.8 bar)
	PVC	150 psi (10 bar) @ 75° F
Minimum Conductivity		20 microSiemens/cm
Calibration Accuracy		+/- 1% of full scale
Output		Square wave pulse, opto isolated, 550 Hz @ 20 ft/sec
Empty Pipe Detection		Software, defaults to zero flow
Regulatory		CE Mark (Stainless Steel, Brass and Standard Power Only)

*Specifications subject to change • Please consult our website for current data (www.seametrics.com).

INSTALLATION

DISTORTED FLOWS

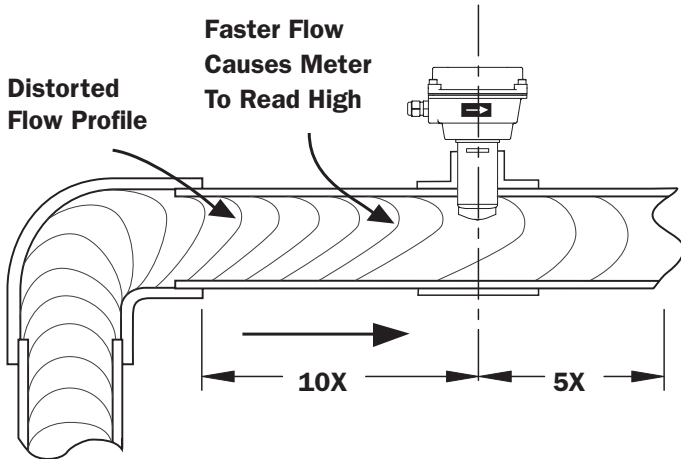

Fitting Installation. EX80-Series meters require special fittings that ensure that the flow sensor is installed to the correct depth. The fitting must be installed in the pipeline before the meter can be installed. For best results, install with at least ten diameters of straight pipe upstream of the meter and five diameters downstream (or more under specific adverse circumstances). See diagrams, next page.

If there is not enough straight run to smooth out the turbulence caused by valves, fittings, and changes in direction, some decrease in accuracy may result. This does not mean that the flow meter's reading is meaningless, however. In some applications (control systems, valve operation, chemical addition), a repeatable reading may be more important than a highly accurate one.

Although EX80-Series PVC meter tees are supplied with some straight pipe, additional straight pipe should be added to meet straight pipe recommendations. It is not advisable to connect a flow-disturbing device (e.g. valve or elbow) directly to the end of these fittings.

A PVC fitting is usually installed by solvent welding. The stainless steel and brass meter fittings have female pipe threads, requiring the appropriate male threaded fittings. Saddle weld fittings (3" and above) require a hole to be cut in the pipe. Recommended hole size is 1-3/4".

Chemical Injection or Fertigation. When any magmeter, by any manufacturer, is used in a chemical injection application (including fertigation), the chemical injection point must be placed downstream of the magmeter OR far enough upstream for complete mixing to occur before the fluid reaches the meter. When unmixed chemical or fertilizer alternates with water passing through the meter, the rapid changes in conductivity may cause sudden spikes and drops in the meter's reading, resulting in inaccurate measurement. The magmeter will restabilize, however, with a steady flow of fluid of uniform conductivity.



Caution: In chemical injection or fertigation applications, install chemical injection point downstream of magmeter, or far enough upstream to allow complete mixing of fluids before the meter.

Meter Installation. After the meter fitting is installed in the pipeline, the meter can be installed in the fitting. After noting the direction of the flow arrow, press the meter into the fitting as far as it will go. Retain the meter in place by inserting the U-clip. The pin can be installed from either side. It may be necessary to rotate the probe back and forth slightly to start the pin into the slots on the probe. Slide the pin in as far as it will go.



Caution: These flow sensors are not recommended for installation downstream of a boiler feedwater pump where installation fault may expose the flow sensor to boiler pressure and temperature. Maximum recommended temperature is 130°F (Plastic), 200°F (Metal).

POSITIONING THE METER

Okay position if there is no air in the pipe

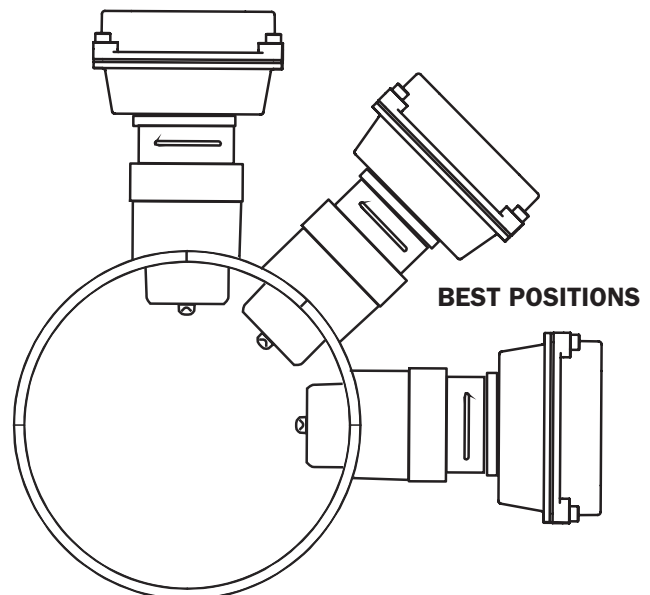

Caution: Never remove the U-clip retainer when the pipe is under pressure. Always remove pressure from the pipe before you attempt to remove the meter. Removal under pressure may result in damage or serious injury.

INSTALLATION

STRAIGHT PIPE RECOMMENDATIONS

(X = pipe diameter)

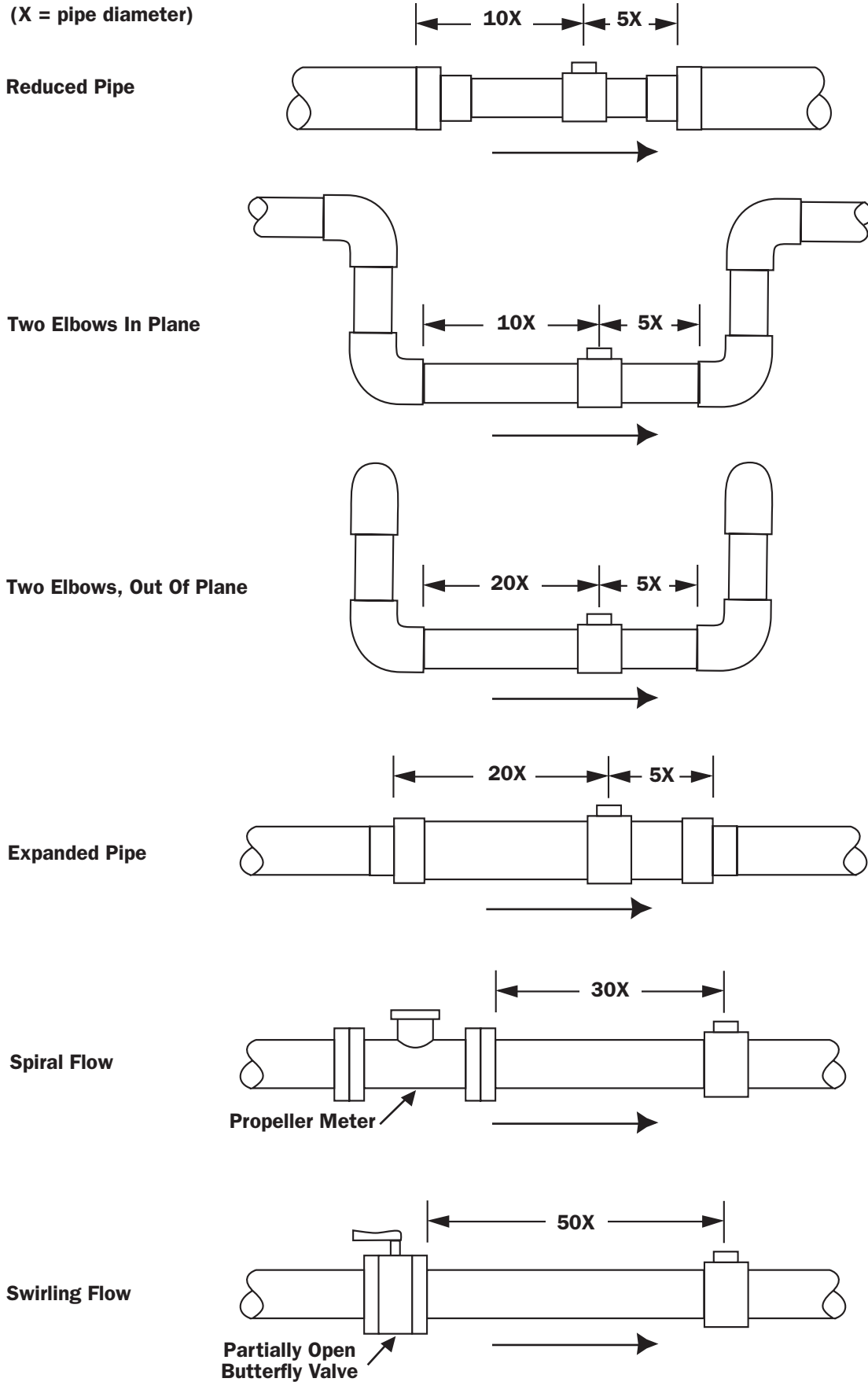

INSTALLATION

FULL PIPE RECOMMENDATIONS

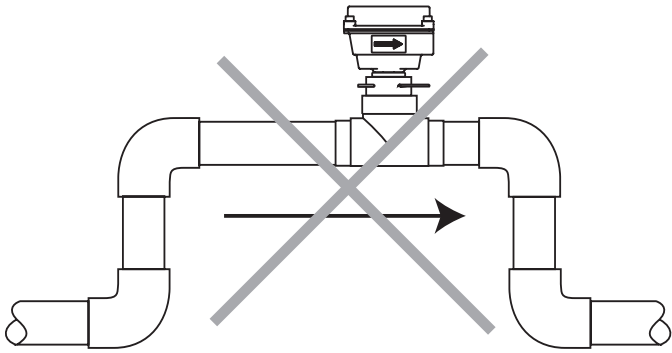

Possible Problem:
Allows air pockets to form at sensor

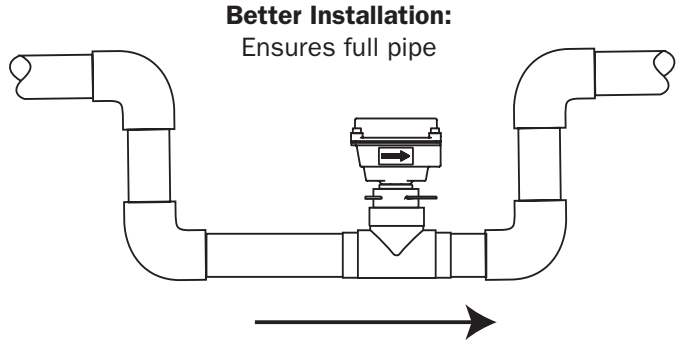

Better Installation:
Ensures full pipe

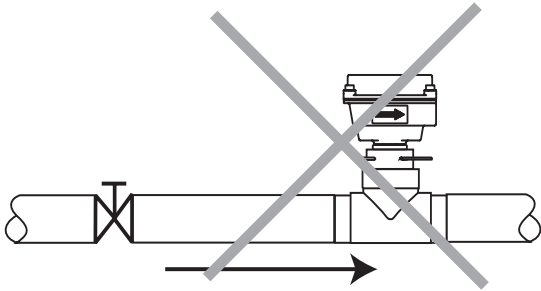

Possible Problem:
Post-valve cavitation can create air pocket

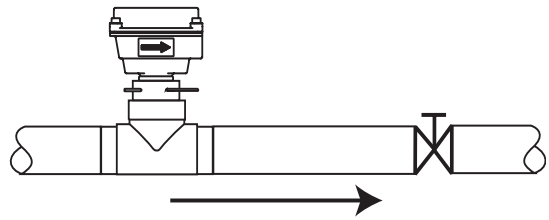

Better Installation:
Keeps pipe full at sensor

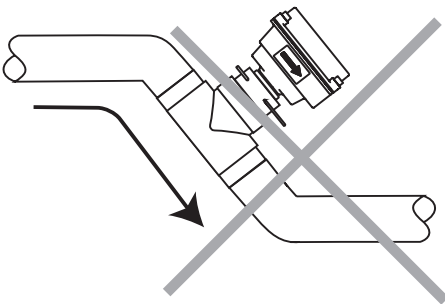

Possible Problem:
Air can be trapped

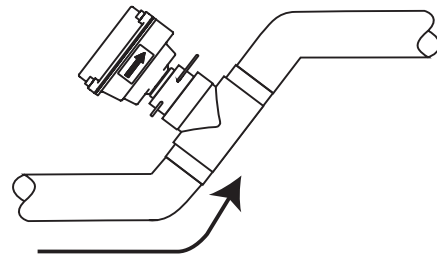

Better Installation:
Allows air to bleed off

ELECTRICAL CONNECTIONS

General Electrical Guidelines:

- Whenever possible avoid running control cables in the same conduit with or bundled with AC power.
- Using shielded cable, be sure to connect shield to ground at power supply end of the cable.
- Avoid routing flow sensor cables in close proximity to a variable frequency drive.
- Recommended power and output wiring is shielded twisted pair 18-22 AWG control cable.
- Recommended voltage is 12-24 Vdc. Note that unregulated power supplies can vary from nameplate voltage by a considerable amount, especially with AC line voltage fluctuation. Therefore 24V power supplies must be regulated.

See the Connections diagrams on the following pages for the appropriate terminals.

Power: A 12 - 24 Vdc power supply capable of at least 250 mA current output is needed.

Forward Flow Output: This open-collector isolated output does not supply power. This pulse is generated in the forward flow direction on the standard unit. (Reverse flow output is available as an option).

Note: This output is limited to 6 mA at 30 Vdc maximum.

Reverse Flow Output: Reverse flow output is available as an option. This open-collector isolated output does not supply power. It functions like a polarity-sensitive switch closure.

Note: This output is limited to 6 mA at 30 Vdc maximum.

Grounding Guidelines:

For best results, use a good quality earth ground, such as metallic water piping or a driven ground, to ensure a good connection to earth ground and good noise suppression.

If the flow sensor is installed in metallic piping, for optimum connection clamp wire to the piping a short distance to one side of the flow sensor using an electrical grounding clamp. Connect the wire to the earth ground and to one of the housing screws.

For Non-Metallic Pipe: Connect one to the housing screws by wire to a good earth ground, such as metallic water piping or a rod driven into the ground.

EX meters are usually unaffected by moderate levels of electrical noise. In some applications performance may be improved by taking the following steps:

- Use shielded twisted pair cable (Belden 8723 or equivalent above ground or Alpha 35482 or equivalent burial).
- Clamp a ferrite bead (Steward 28A2029-OAO or equivalent) on meter signal/power wire within 3/4" of the meter strain relief (tape or tie wrap in place if necessary). See diagram below.
- IMPORTANT - Connect the cable shield ground wire to ground, ONLY at power supply end of cable.

GROUNDING DIAGRAM

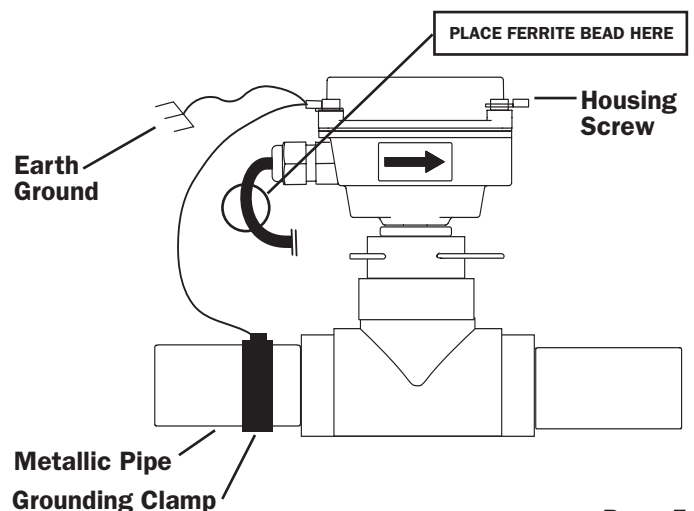

CONNECTIONS DIAGRAMS

COUNTER OR PLC

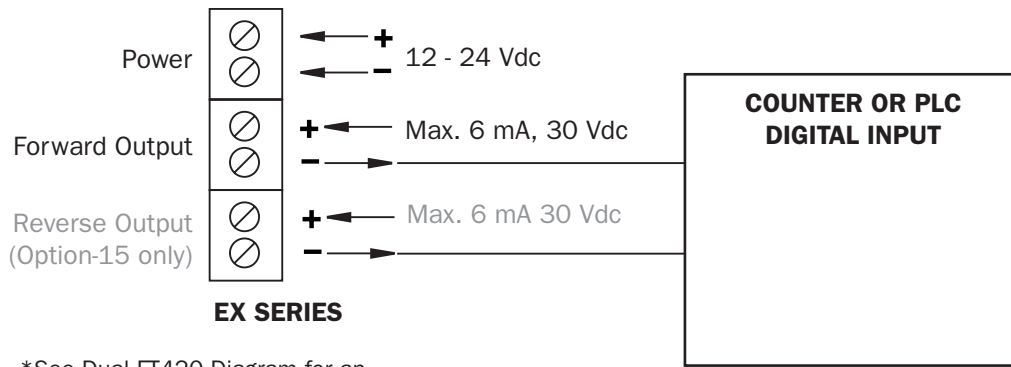

*See Dual FT420 Diagram for an example of bidirectional connections.

A055 4-20 mA OUTPUT

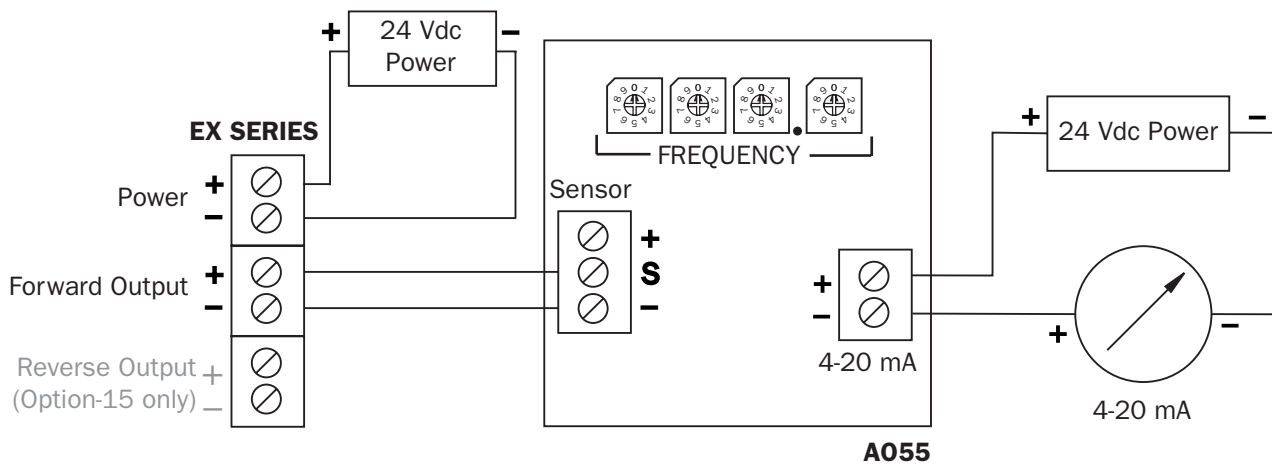

*See Dual FT420 Diagram for an example of bidirectional connections.

FT520 CONTROLLER

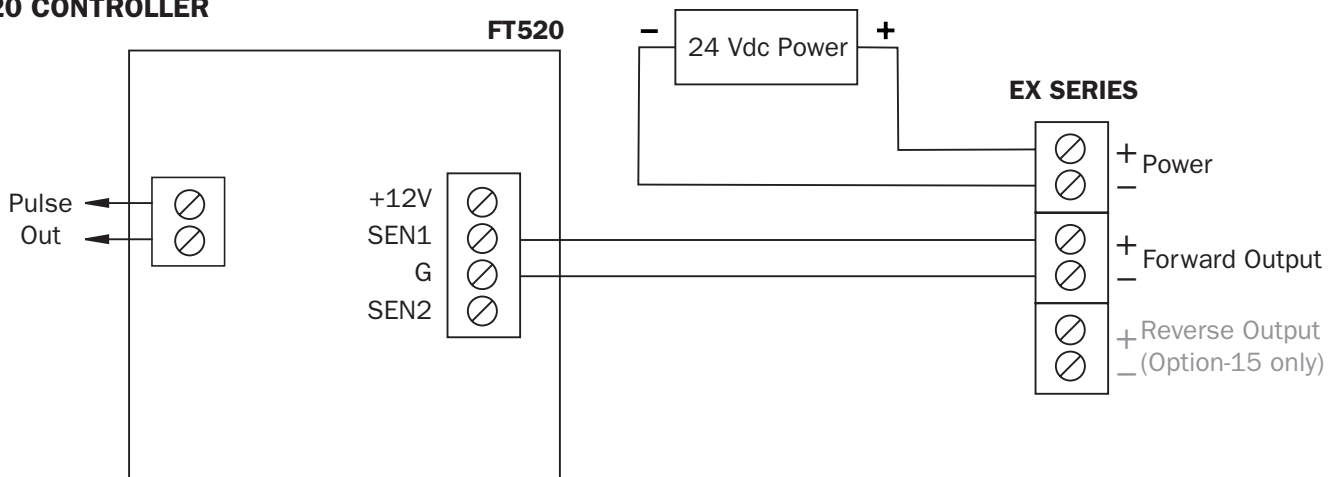

*See Dual FT420 Diagram for an example of bidirectional connections.

CONNECTIONS DIAGRAMS

FT420 DISPLAY AND PROPORTIONAL FEED

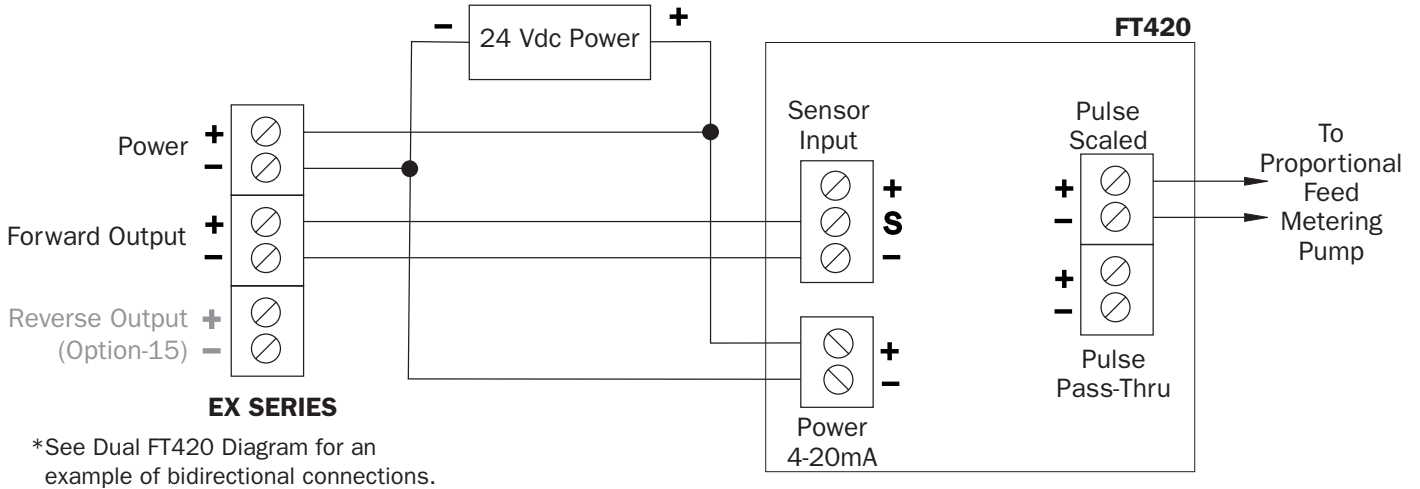

FT420 DISPLAY AND 4-20 mA OUTPUT

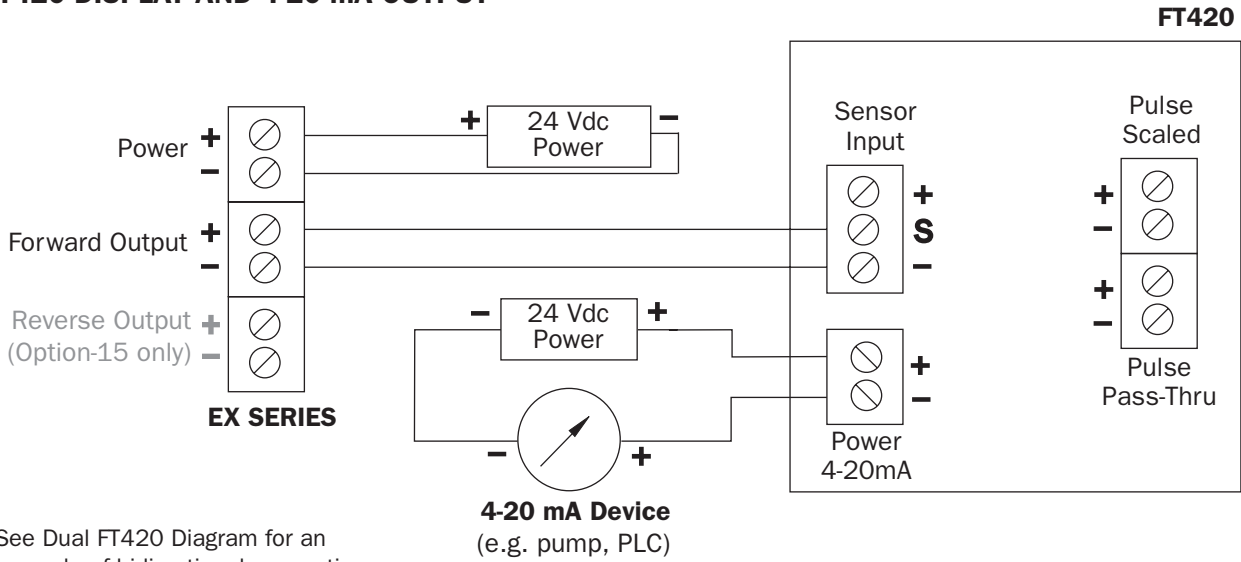

DUAL FT420 DISPLAYS (Example of Bidirectional Connection)

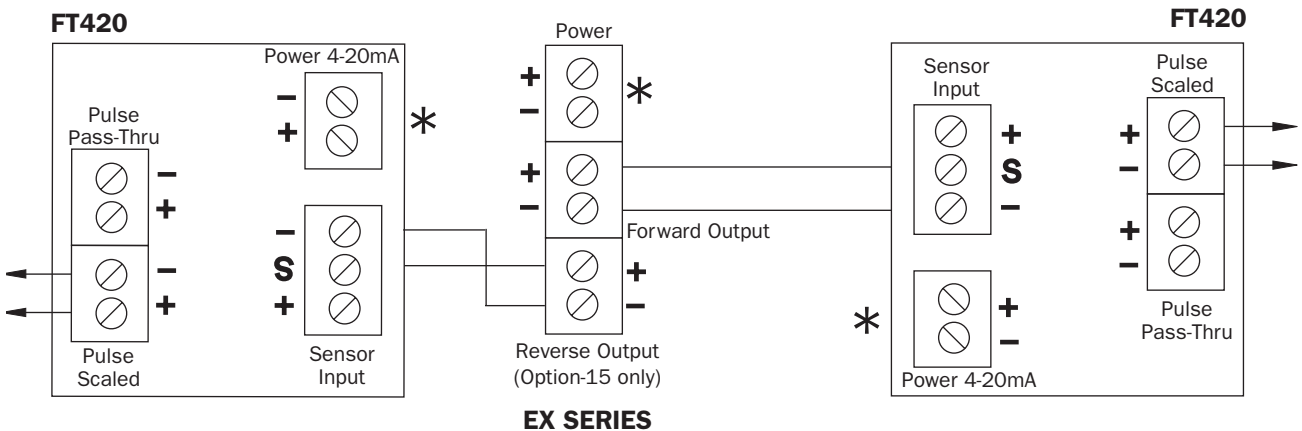

*Requires 12-24 Vdc power source.

CONNECTIONS DIAGRAMS

DL76 DATA LOGGER

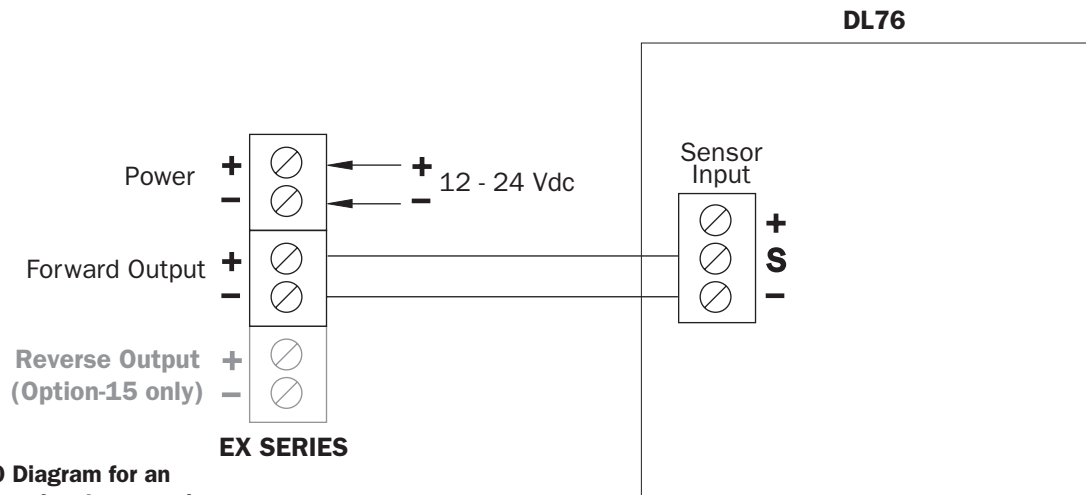

*See Dual FT420 Diagram for an example of bidirectional connections.

FT420/DL76

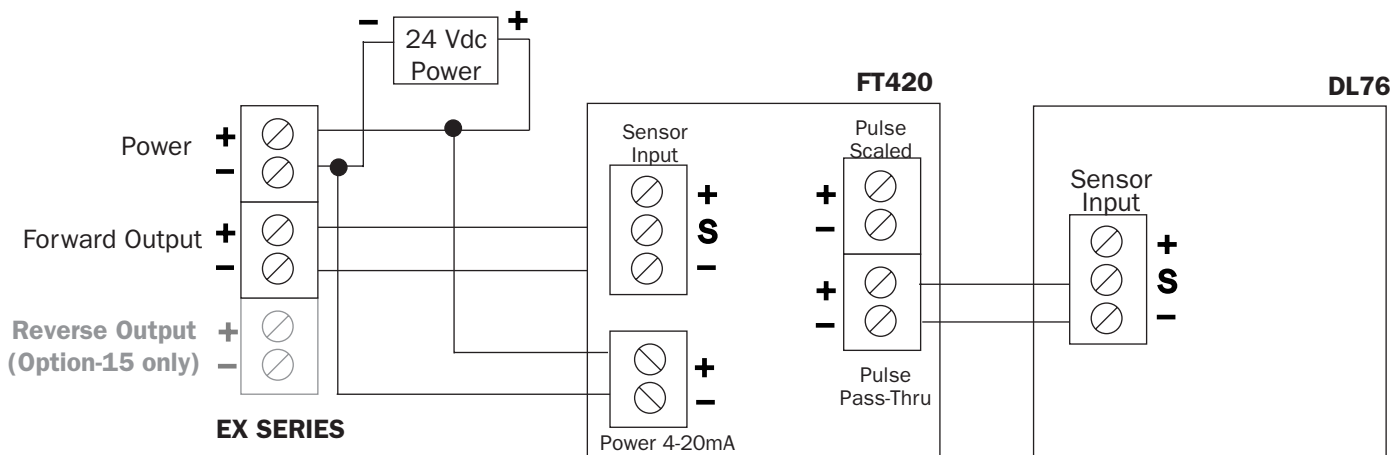

*See Dual FT420 Diagram for an example of bidirectional connections.

OPERATION & MAINTENANCE

Zero Adjustment. When the EX80-Series is powered up and there is no flow, there should be no output pulses (or, if connected to the FT420, flow rate should read “0”). If there are pulses it may be necessary to adjust the flow meter under no-flow conditions after it has been installed. This should only be done if the indicated flow is low, near the lower cutoff.

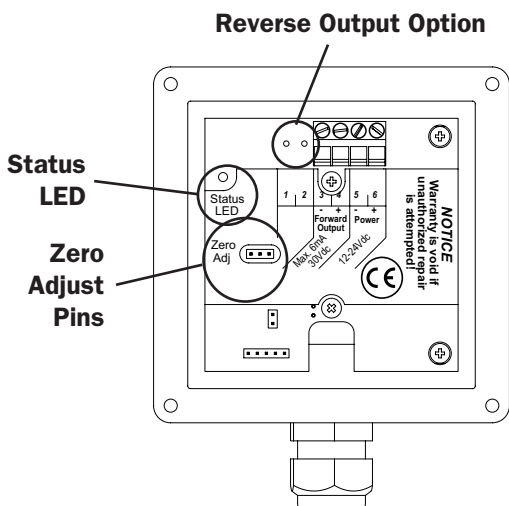

To perform the adjustment, after determining that there is a **full pipe with no flow**, short between the two pins marked “Zero Adjust”. A red LED light will come on for approximately 50 seconds and then go out. The zero adjustment is completed.

Minimum Flow. As with any other flow sensor, there is a rate below which the EX80-Series sensor cannot read. Check the flow rate table below for the minimum flow rate detectable by the sensor for a given pipe size.

FLOW RATE (GPM)

Nominal Pipe Size	1"	1-1/2"	2"	3"	4"	6"	8"	10"	12"
• Min @ 0.2 ft/sec	.69	1.5	2.7	6.2	11	25	43	68	99
• Max @ 20 ft/sec	49	110	196	440	783	1760	3130	4900	7050

Presence of Flow Indication. To assist in troubleshooting, the “Status LED” has two blinking modes in normal operation. When there is no flow detectable by the meter (below minimum threshold) the LED blinks every 8.0 seconds. When there is detectable flow, the same indicator blinks every 3.0 seconds.

Filtering. The software of the EX80-Series sensor filters out electrical noise and averages sudden variations in the flow to smooth the output. It takes a matter of seconds for the flow sensor to get up to full output when it is powered up or when flow begins.

Electrode Coating. Grease or other adhering, non-conductive materials can stop flow detection if the electrodes become heavily coated. To clean the electrodes, remove the sensor from the pipe and gently scrub the electrodes (three silver bumps) on the reading face of the flow sensor. A mild soap (dishwashing liquid for example) can be used to aid the cleaning process.

Calibration (“K-factor”). The K-factor represents the actual number of pulses per gallon the meter produces during a flow test. This number can be entered into your electronic control to make it read properly. If the EX80-Series meter is ordered with a **tee fitting**, it is factory-calibrated in the fitting and the K-factor is indicated on the side of the fitting (see diagram).

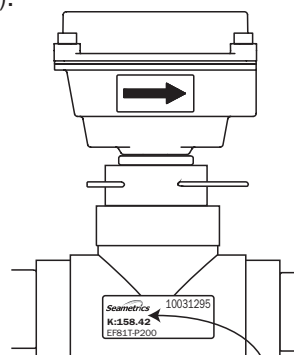

Find Your K-Factor Here

If the EX80-Series meter is ordered with a **saddle or weldolet fitting**, find your K-factor in the chart below.

	K-FACTORS SADDLES & WELDOLETS					
	3"	4"	6"	8"	10"	12"
PVC/Steel Sch. 40	70.397	40.985	18.130	10.497	6.674	4.709
PVC/Steel Sch. 80	78.748	45.360	20.084	11.495	7.322	5.184
Stainless Steel (10S)	62.385	36.626	16.510	9.642	6.173	4.373
Stainless Steel (40S)	70.397	40.985	18.130	10.497	6.674	4.661
Copper Tubing (Type L)	76.371	43.552	19.513	11.201	7.230	5.016
Copper Tubing (Type K)	78.371	44.638	20.223	11.622	7.500	5.239
Brass Pipe	70.672	41.517	17.778	10.445	6.674	4.661
Duct. Iron (Class 52)	57.376	37.320	16.915	9.503	6.197	4.325

NOTE: K-factors are in Pulses/gallon. For Pulses/Liter, divide by 3.785.

CAUTION & TROUBLESHOOTING



Caution: The electronics of the EX-Series meters are not field-repairable.
Warranty is void if unauthorized repair is attempted

TROUBLESHOOTING

Problem	Probable Cause	Try...
No pulse output	Pipe not full	Check plumbing
	Below minimum flow cutoff	Check the presence of Flow LED (see pg. 9)
	Unit not grounded	Connect to earth ground
	Excessive electrical noise	Check for proper electrical wiring
	No power	Check for power across power input terminals
	Flow reversed	Note flow direction arrow, reverse direction of meter
	Power reversed	Reverse connections
	Output connections reversed	Change output connections
Output pulses incorrect	Fluid conductivity <20 microSiemens/cm	Select another flow meter
	Missing or incorrect ground wire	Check for proper ground
	Excessive electrical noise	Check for proper electrical wiring
	Empty pipe	Check for full pipe or install meter in the vertical position
	Not enough straight pipe	Check for ten diameters upstream AND five diameters downstream
Jumpy reading	Rapidly changing conductivity (in chemical injection or fertigation applications)	Install chemical injection line downstream of magmeter (or far enough upstream to allow complete mixing of fluids before meter)



Seametrics Incorporated • 19026 72nd Avenue South • Kent, Washington 98032 • USA
(P) 253.872.0284 • (F) 253.872.0285 • 1.800.975.8153 • www.seametrics.com