

# PE102

*Seametrics*

## LOW FLOW MAGMETER INSTRUCTIONS



PE102 LOW FLOW MAGMETER INSTRUCTIONS

**ISO** 9001:2008  
CERTIFIED

## GENERAL INFORMATION, FEATURES and SPECIFICATIONS

The **PE102 magmeter** is designed for low-flow chemical injection or difficult-to-meter applications with pulsating metering pumps in 3/4" to 1/4" pipe/tube. The housing is made of sturdy splashproof HDPE plastic.

With no moving parts, the PE102 can handle fluids containing particulate matter without clogging or jamming, keeping maintenance at a minimum. With no metallic parts (100% PVDF body and PVDF carbon fiber-filled electrodes), the meter is corrosion-resistant and compatible with a wide range of chemicals. Accuracy is maintained with conductive fluids (>20 microSiemens) of varying viscosities and densities.

The PE meter is compact enough to fit most pump/injection systems. With zero straight pipe required after an elbow, it can be easily mounted in tight spaces. The mounting bracket adds stability.

The PE meter has optocoupled current sinking or current sourcing pulse output that can be connected to the Seametrics FT420 rate/total display or FT520 batch processor, as well as a 4-20 mA loop for powering analog devices. Outputs and power are provided through a cable with 8-pin female circular connector. Order the required cable/connector separately from Seametrics (see How to Order, back page) or from another vendor (one possibility is [www.turck-usa.com](http://www.turck-usa.com), part #RKC 8T-6/S618).

### FEATURES

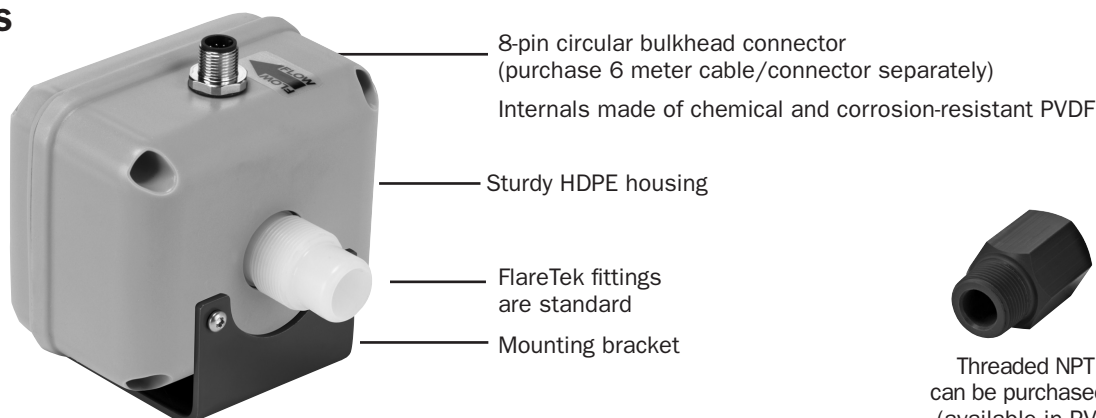

### SPECIFICATIONS\*

<b>Pipe Size</b>		3/4", 1/2", 3/8", 1/4"***
<b>Fittings</b>		FlareTek fittings standard in 3/4" or 3/8" flowbody; NPT threaded adapters also available
<b>Materials</b>	<b>Body</b>	PVDF
	<b>Electrodes</b>	PVDF carbon fiber-filled
	<b>Ground</b>	PVDF carbon fiber-filled
	<b>Housing</b>	HDPE with glass fiber
	<b>Fittings (FlareTek)</b>	PVDF
	<b>Adapters (NPT)</b>	PVC or PVDF
	<b>O-Rings (for NPT)</b>	EPDM or Viton
<b>Temperature</b>	<b>Ambient</b>	0° to 130° F (-18° to 54° C)
	<b>Fluid</b>	32° to 200° F (0° to 93° C)
<b>Pressure</b>		150 psi
<b>Flow Range</b>	<b>-075</b>	20 GPM Max. (0.2 GPM cut off)
	<b>-038</b>	3 GPM Max. (0.03 GPM cut off)
<b>Accuracy</b>	<b>-075</b>	+/- 1%, +/- 0.005 GPM of reading across rated range
	<b>-038</b>	+/- 1%, +/- 0.002 GPM of reading across rated range
<b>Output Signal</b>		Optocoupled current sinking or current sourcing pulse output: 30 Vdc, 5 mA max 4-20 mA current loop: 7 Vdc plus load voltage drop min; 50 Vdc max
	<b>-075</b>	PE102-075: 500 pulses/liter (1892 pulses/gallon),
	<b>-038</b>	PE102-038: 1,000 pulses/liter (3785 pulses/gallon).
<b>Power</b>		10-15 Vdc, 150 mA (linear power supply recommended)
<b>Conductivity</b>		>20 microSiemens
<b>Empty Pipe Detection</b>		Hardware/software, conductivity-based
<b>Environmental</b>		NEMA 4X standard; IP 66 Splashproof standard

\*Specifications subject to change • Please consult our website for current data ([www.seametrics.com](http://www.seametrics.com)).

\*\*Requires adaptors

# INSTALLATION and CONNECTIONS

## INSTALLATION

**Positioning.** The PE102 can be mounted vertically or horizontally. It is important to choose a position that will ensure full pipe. (Under certain conditions of empty or partially-full pipe the meter may give a pulse out when there is no flow.) With a zero straight pipe requirement after an elbow, the PE meter can be installed in tight spaces.

**Mounting.** The PE102 may be supported by its piping connections IF the piping is rigid. The meter and pipe must be perfectly aligned with no flexion at the fittings to prevent damage to the meter and leakage. It is highly recommended to use the mounting bracket provided. The mounting bracket uses two #8 screws on a 1.5" center.

**Piping.** Metal pipe, metal tube, or plastic tubing can be used with the meter. The standard FlareTek fittings can be used with or without NPT adapters on 3/4" or 3/8" pipe. If used, NPT adapters should be hand-tightened onto the fittings to avoid damage to internal O-ring seals. Thoroughly clean the pipe threads and nose and apply Teflon tape to adapter threads. Hold fittings/adapters with a wrench while tightening the pipe to prevent damage to the meter. If using FlareTek fittings, follow the installation instructions provided with your flare tool.

**Power Supply.** A 12 Vdc linear, regulated power supply with an output current of at least 0.25A is recommended. If a switching power supply must be used, consult Seametrics for approved manufacturer's model numbers.

## CONNECTIONS

Power and signal connections are provided through the 8-pin male bulkhead connector on the meter housing. A cable with an 8-pin female circular connector must be purchased separately from Seametrics or another vendor (one alternative is [www.turck-usa.com](http://www.turck-usa.com), part #RKC 8T-6/S618). See the Pin Assignment and Connections diagrams below. If using a Seametrics cable or the alternative given, the wire colors in the table below will be accurate; if using another vendor or part #, use the pin assignments as your wiring guide.

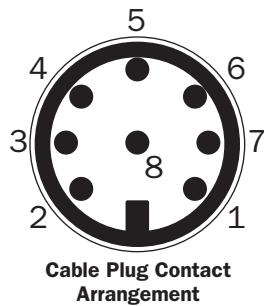

Pin#	Function	Color
1	Pulse (-)	White
2	Ground	Brown
3	Pulse (+)	Green
4	4-20 (+)	Yellow
5	Not Used	Grey
6	Not Used	Pink
7	4-20 (-)	Blue
8	Power (+)	Red

In addition, it is necessary for proper operation to ground the unit to a good quality earth ground. Assure negative power supply is grounded to earth and to the entire electrical/mechanical system. If metal piping is used, jumper inlet and outlet pipes together and connect to ground for best results in metering accuracy.

### Pulse Output Only with FT520

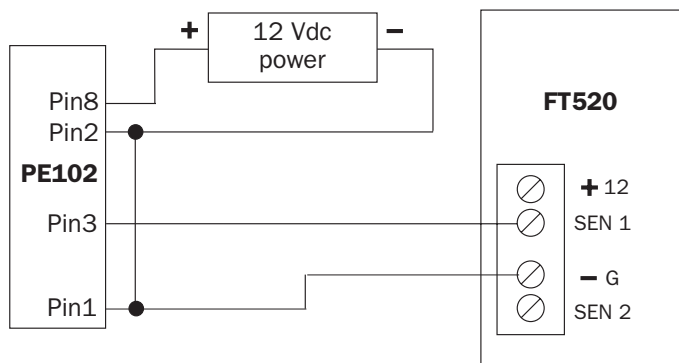

### 4-20 mA Device and FT420 with Single Power Supply

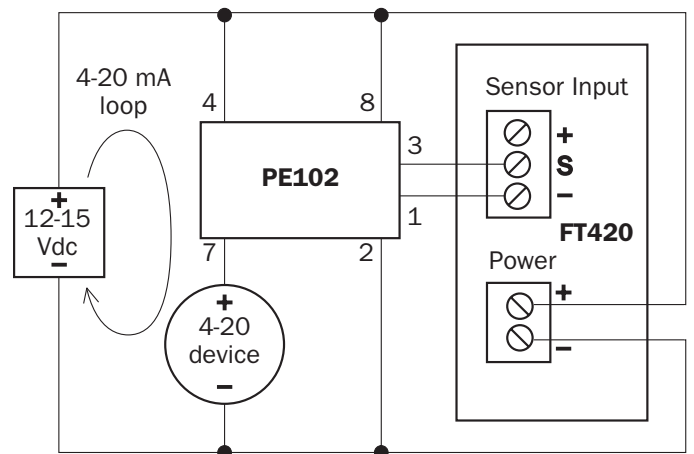

### Dual Power Supply with Loop Isolation

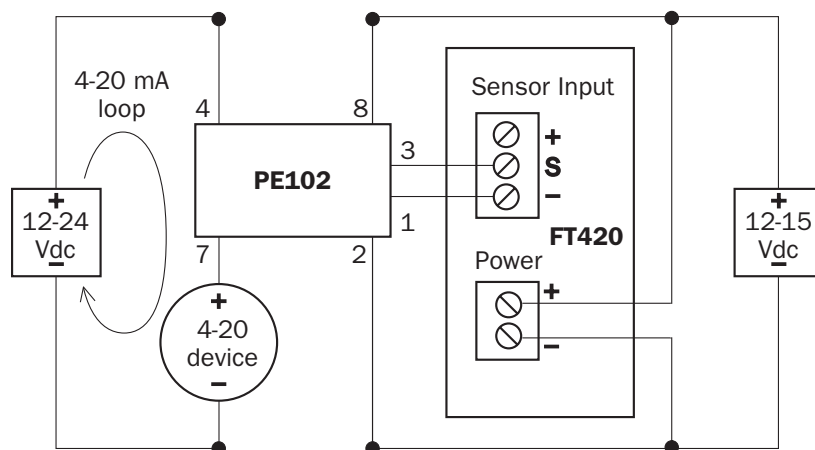

## OPERATION and TROUBLESHOOTING

---

### OPERATION

The meter will output one pulse when powered up. The newly-installed meter takes from a few seconds to a minute for the signal to stabilize at startup, especially if it has been dry. In normal operation, keep the meter filled with fluid and powered on to prevent this delay. When the meter is mounted properly, an empty pipe detection feature will normally detect absence of liquid in the pipe and register zero flow.

The 4-20 mA signal outputs 4 mA at zero flow and 20 mA at 20 gallons/minute flow or 3 gallons per minute, depending on model. The pulse signal is a 50% duty cycle pulse set at PE102-075: 500 pulses/liter (1892 pulses/gallon), PE102-038: 1,000 pulses/liter (3785 pulses/gallon).

### TROUBLESHOOTING

Problem	Probable Causes	Try...
No output	Reversed flow direction Empty pipe Flow rate below minimum Loose or incorrect wiring Fluid conductivity too low Electrical noise	Reverse flow connections Check piping conditions Select a different flowmeter Check electrical connections Select a different flowmeter Relocate meter or reduce noise
Flow rate incorrect	Fluid conductivity too low Empty pipe Electrical noise	Select another flowmeter Check piping conditions Relocate meter or reduce noise

