

TX80-Series

Seametrics

FLOW SENSOR INSTRUCTIONS

- TX81
- TX82



TX80-SERIES FLOW SENSOR INSTRUCTIONS

TABLE OF CONTENTS

General Information

Specifications, Features Page 1

Installation

Distorted Flows, Fitting Installation, Meter Installation, Positioning the Meter Page 2

Straight Pipe Recommendations Page 3

Full Pipe Recommendations Page 4

Electrical Connections

FT415/FT420, Connecting to PLC's Page 5

Operation

Modularity, Output, Fittings, Minimum Flow, Flow Range Table,
Calibration ("K-Factor"), K-Factor Chart Page 6

Maintenance

Rotor Replacement, Signal Troubleshooting, Sensor Replacement Page 7

Parts Explosion

Parts List Page 8

Troubleshooting

Problem, Probable Cause Page 9

TABLES AND DIAGRAMS

Specifications, Features Page 1

Distorted Flows, Positioning the Meter Page 2

Straight Pipe Recommendations Page 3

Full Pipe Recommendations Page 4

Connections Diagram Page 5

Flow Range Table, K-Factor Chart Page 6

Rotor Replacement Page 7

Parts Explosion, Parts List Page 8

Troubleshooting Page 9

GENERAL INFORMATION, SPECIFICATIONS, FEATURES

GENERAL INFORMATION

The TX80-Series are insertion turbine meters designed for use in 1-1/2" to 8" pipe. High-quality jewel bearings and precision shafts ensure long life and low friction. Available in 316 stainless steel, brass, PVC and polypropylene, sensor bodies are machined from solid rod for maximum low-flow performance. The TX80-Series use special fittings that ensure ease of installation and correct depth setting in the pipe.

The rotation of the turbine is detected by a non-drag Hall-effect sensor. Output is a pulse-type square wave, which can be sent long distances (up to 2,000 feet) without a

transmitter. This signal can be connected directly to Seametrics controls and displays, as well as PLC's, counters, and computer cards.

Seametrics TX80 meters are ideal for chemical proportioning applications. If no display is required, a simple divider such as the PD10 provides adjustable pump pacing. For rate and total display, as well as pump pacing, the FT420 flow indicator can be mounted directly on the TX80-Series, or remotely on a wall or panel. The FT415 offers a battery-operated rate/totalizer where power is not available.

SPECIFICATIONS*

Materials	Body	Polypropylene, brass or stainless steel		
	Rotor Assembly	Polypropylene rotor/carbide shaft (PVDF rotor/ceramic shaft optional)		
	Bearings	Ruby jewel		
	O-Ring	EPDM (Viton optional)		
Rotor Pickup	GMR (Giant Magnetoresistive Sensor)			
Maximum		Brass	316 SS	PVC/Polypro
	Pressure	200 psi (14 bar)	250 psi (17 bar)	175 psi (12 bar) at 75°
	Temperature	200° F (93° C)		130° F (55° C) at 0 psi
Flow Range	0.2 to 30 ft./sec.			
Calibrated Accuracy	+/- 1.5% of full scale			
Signal	Current sinking pulse, 20 mA max, 30 Vdc max (Micropower option: Pulse output swings between supply voltage and 0 Vdc)			
Power	6-30 Vdc @ 8 mA (Micropower option: 3.5-16 Vdc @ 0.3 mA max)			
Cable	22 AWG, 3 Con, 18'; 2000' max run			
Regulatory	 Mark (Stainless Steel, Brass and Standard Power Only)			

*Specifications subject to change. Please consult our website for the most current data (www.seametrics.com).

FEATURES



Caution: U-clip must be installed before use.

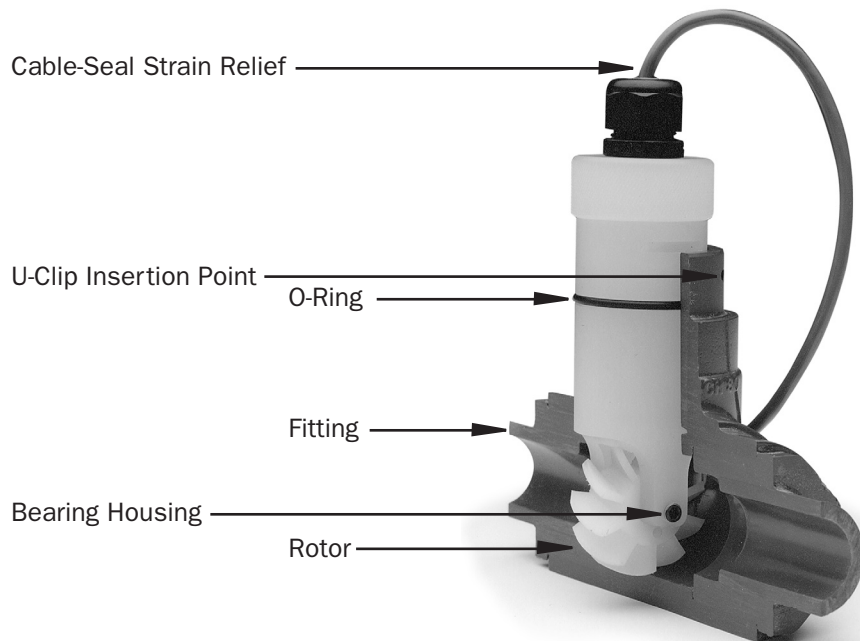

INSTALLATION

DISTORTED FLOWS

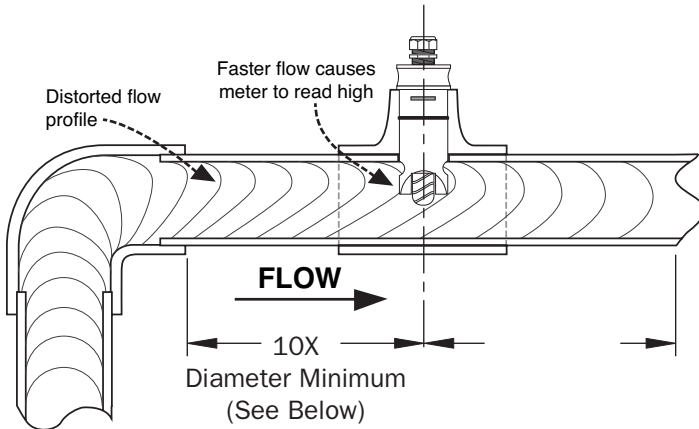

Fitting Installation. TX80-Series meters require special fittings. The meter fitting must first be installed in the pipeline. Straight pipe of at least ten times the diameter upstream of the meter and five diameters downstream is strongly recommended in order to achieve proper accuracy. These are minimum values. As the diagrams on the next page will show, you may need more straight run under specific adverse circumstances.

If you can't provide enough run to smooth out the turbulence caused by valves, fittings, and changes in direction, some decrease in accuracy may result. This does not mean that the flow meter's reading is meaningless, however. In some applications (for instance, where the flow meter is part of a control system, operating a valve or controlling chemical addition), a repeatable reading may be more important than a highly accurate one.

TX80-Series PVC meter tees are supplied with some upstream straight pipe. The length provided may be less than ten diameters upstream and five downstream. It is not advisable to connect directly to the end of these fittings with a flow-disturbing device such as a valve or elbow. If possible, straight pipe should be added to the upstream end of these fittings.

A PVC fitting is usually installed by solvent welding. The stainless steel and brass meter fittings have female pipe threads, requiring the appropriate male threaded fittings.

Saddle fittings (size 3" and above) require a hole to be cut in the pipe. The recommended hole size is 1-3/4".

Meter Installation. After the meter fitting is installed in the pipeline, the meter can be installed in the fitting. Press the meter into the fitting as far as it will go. Retain the meter in place by inserting the u-pin. The pin can be installed from either side. It may be necessary to rotate the probe back and forth slightly to start the pin into the slots on the probe. Slide the pin in as far as it will go.

POSITIONING THE METER

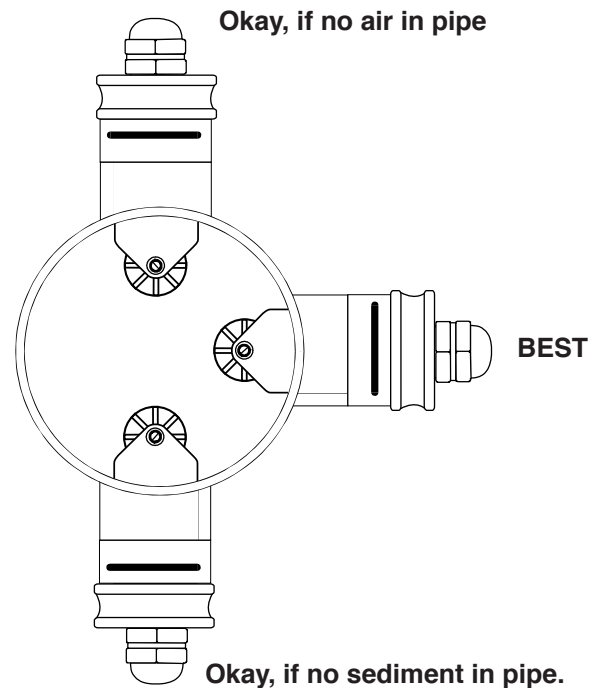

Caution: Never remove the u-clip retainer when the pipe is under pressure. Always remove pressure from the pipe before you attempt to remove the meter. Removal under pressure may result in damage or serious injury.

INSTALLATION

STRAIGHT PIPE RECOMMENDATIONS

(X = diameter)

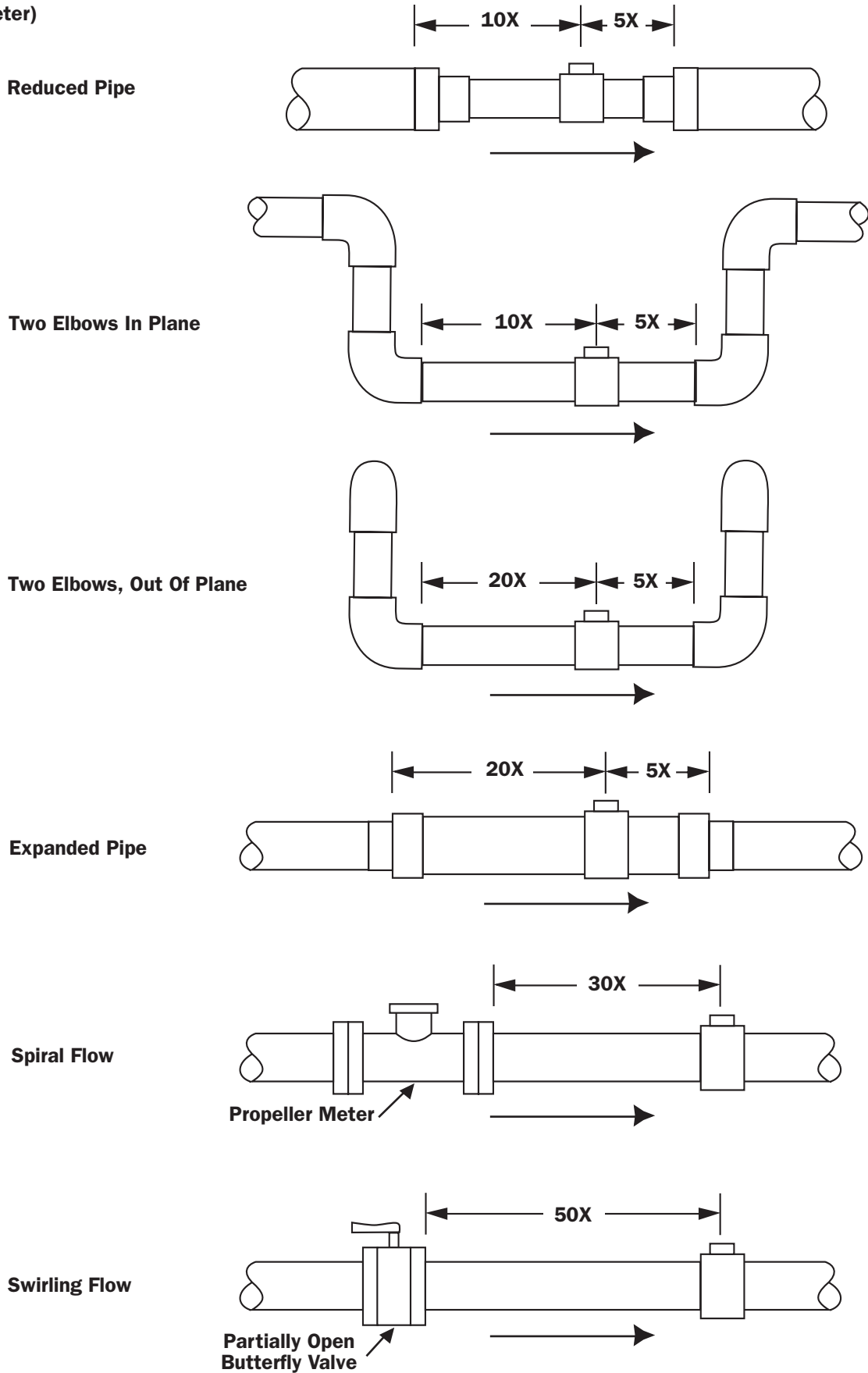

INSTALLATION

FULL PIPE RECOMMENDATIONS

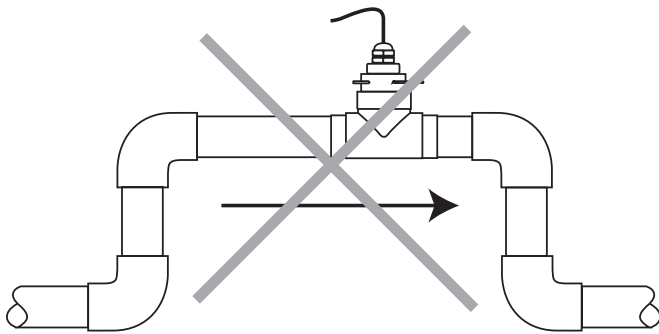

Possible Problem:
Allows air pockets to form at sensor

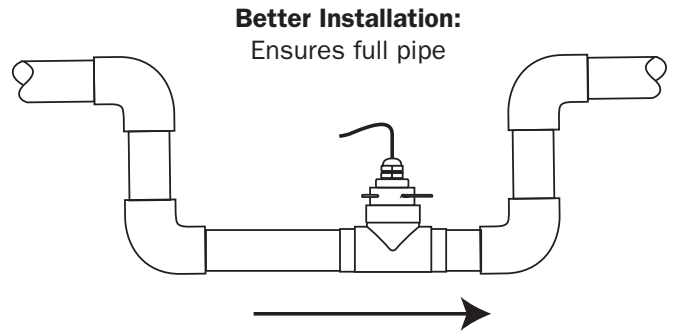

Better Installation:
Ensures full pipe

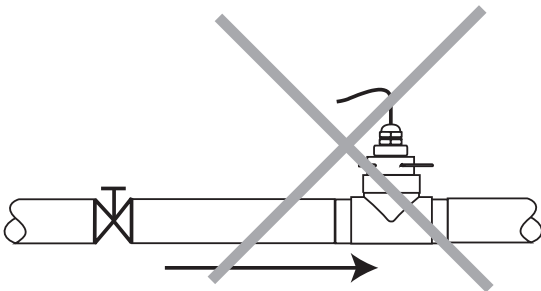

Possible Problem:
Post-valve cavitation can create air pocket

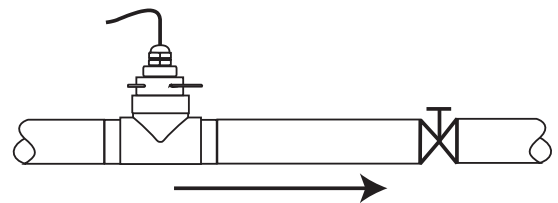

Better Installation:
Keeps pipe full at sensor

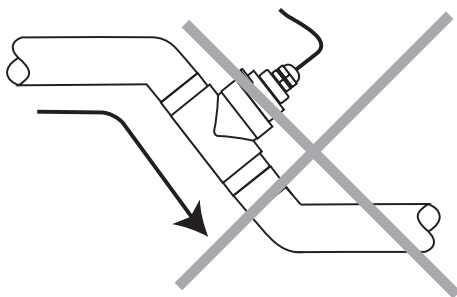

Possible Problem:
Air can be trapped

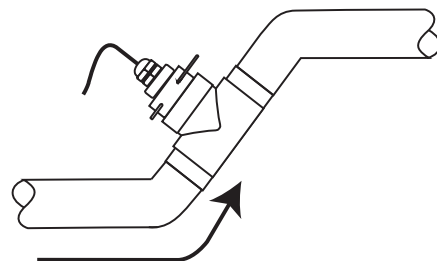

Better Installation:
Allows air to bleed off



Caution: These flow sensors are not recommended for installation downstream of the boiler feedwater pump where installation fault may expose the flow sensor to boiler pressure and temperature. Maximum recommended temperature is 130°F (Plastic), 200°F (Metal).

CONNECTIONS DIAGRAMS

FT415 Standard Connections

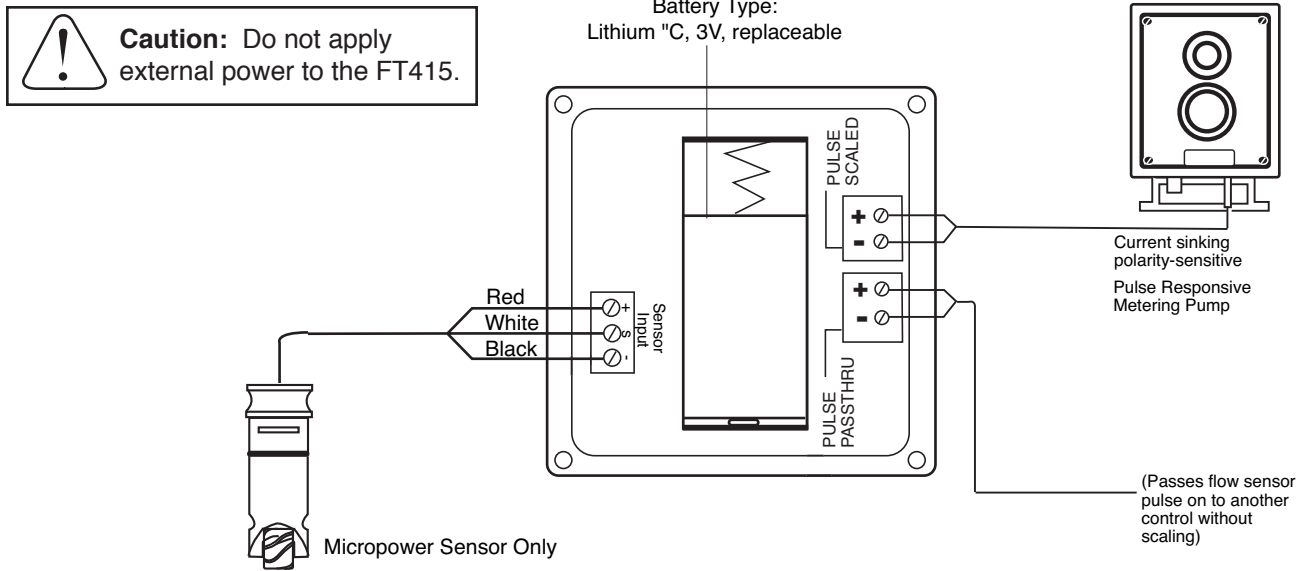

Connections for FT420/3-Wire Mechanical Meter

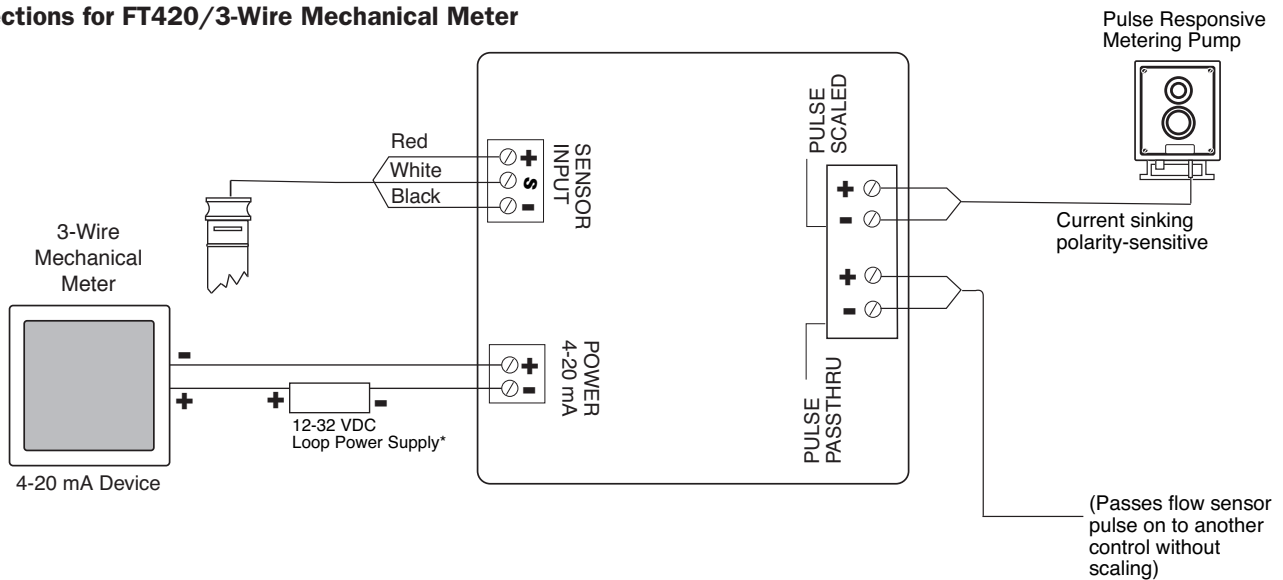

Connecting to PLC's and other non SeaMetric Controls

Input Designed for Current Sinking (NPN) Devices

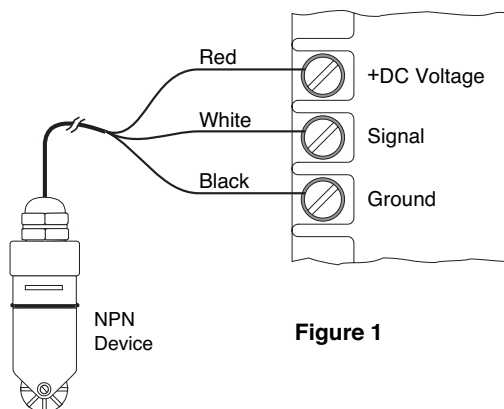

Input Designed for Current Sourcing (PNP) Devices

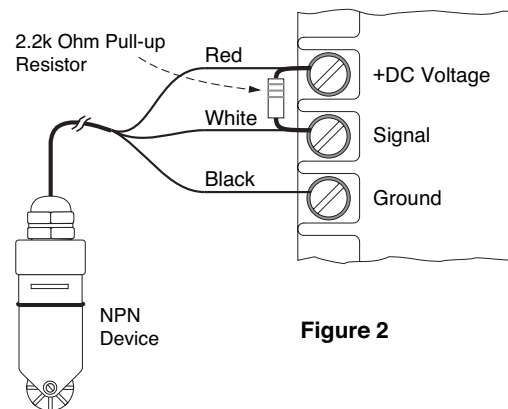

OPERATION

Modularity. Any of the TX80-Series flow sensors can have electronic modules mounted directly to them, either at the time of order or by adding an adaptor kit in the field (part number MK10). Alternatively, the flow sensor and indicator or transmitter can be installed remote from each other. The FT420 is an indicating transmitter (rate, total, 4-20 mA output), and the A055 is a blind 4-20 mA transmitter. For data logging, add the DL76. The FT520, which provides batching and other functions, is suitable for remote installation.

Output. The output is a current-sinking pulse (square wave) compatible with many controls in addition to the Seametrics indicators and transmitters. The most common of these are water treatment controllers and programmable logic controllers (PLC's). For these units, it is sometimes necessary to provide a pull-up resistor if the controller does not provide for a current-sinking output. (See the section on "Connecting to PLC's and other controllers" before connecting to a non-Seametrics control.)

Minimum Flow. As with any other flow sensor, there is a rate below which the TX80-Series sensor cannot read. Check the flow rate table below for the minimum flow rate detectable by the sensor for a given pipe size.

Flow Range (GPM)

	1-1/2"	2"	3"	4"	6"	8"
Min	1.1	2.1	4.6	7.9	18	31
Max	190	314	691	1190	2700	4680

Calibration ("K-factor"). The K-factor represents the actual number of pulses per gallon the meter produces during a flow test. This number can be entered into your electronic control to make it read properly. If the TX80-Series meter is ordered with a **tee fitting**, it is factory-calibrated in the fitting and the K-factor is indicated on the side of the fitting (see diagram).

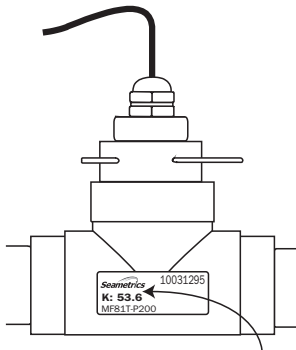

Find Your K-Factor Here

Fittings. Since the TX80-Series sensors are not adjustable, they must be purchased with fittings appropriate to the application. The TX81 is sized for fittings of 1 1/2" to 4". The TX82 is for fittings of 6" and 8". Each fitting insures that the flow sensor is installed at the correct point. Every flow sensor and every tee fitting is wet calibrated. Saddle fittings are normally not wet calibrated, because they are field-installed on a pipe. In PVC however it is possible to order a saddle pre-installed on a standard length of pipe, in which case the entire assembly is wet-calibrated. For all other saddles, the K-factor (pulses per gallon) is established through testing with various standard schedules of pipe and provided with the saddle.

TX80 SERIES K-FACTORS FOR SADDLE & WELDOLET FITTINGS				
	3"	4"	6"	8"
PVC/Steel Sch. 40	17.410	10.110	4.457	2.133
PVC/Steel Sch. 80	19.486	11.195	4.94	2.336
Stainless Steel (10S)	15.420	9.030	4.057	1.958
Stainless Steel (40S)	17.410	10.110	4.457	2.133
Copper Tubing (Type L)	18.895	10.746	4.799	2.276
Copper Tubing (Type K)	19.392	11.015	4.975	2.362
Brass Pipe	17.478	10.242	4.37	2.122
Duct. Iron (Class 52)	14.176	9.202	4.157	1.738



Caution: Never remove the u-clip retainer when the pipe is under pressure. Always remove pressure from the pipe before attempting to remove the meter. Removal under pressure may result in damage or serious injury.

Rotor Replacement. It is unusual for a rotor to require replacement due to damage sustained in normal service. More commonly, the meter is dropped while it is out of the pipe. Another reason for rotor replacement is shaft wear after long service. Rotors are easily field-replaced.

To install a rotor, follow these steps:

1. Unscrew the threaded bearing housings to expose the shaft ends. If bearings are being replaced, back them completely out.
2. Remove the rotor. Put the new rotor in its place.
3. Thread in one bearing housing part way, then the other. Take care to start the end of the shaft into the bearing hole before tightening further.
4. Screw in bearing housings until they bottom.
Note: Do not use excessive force.
5. Check for free spin. Blowing lightly on the rotor should result in it spinning rapidly and coasting to a smooth stop.

For a TX sensor which has the -05 option (ceramic shaft/Kynar rotor), the procedure is slightly different. With this option, the bearings are in the rotor and a half-shaft comes in from either side. As a result, the parts which are removed with the screwdriver are shaft screws rather than bearings. The steps are essentially the same, and it is again important to be sure that the shaft is in the bearing hole before tightening.

Signal Troubleshooting. The flow sensor has only one moving part, the rotor. If this is turning properly and there is no signal, the magnetic sensor is not operating properly. To check the signal, apply 12 Vdc regulated* power to the red (+) and black (-) leads. Set a multimeter to voltage reading. Put the positive multimeter lead on the red wire and the negative lead on the white wire. Slowly turn the rotor. Voltage reading should swing between +12 Volts and 0 Volts as the rotor turns. If it does not, the solid-state magnetic sensor is not working properly. Checking for continuity is not a useful test of these sensors.

***NOTE:** An unregulated power supply can exceed max voltage of micro powered sensor (gray cable) and damage sensor.

Sensor Replacement. It is very unusual for a sensor to require replacement in normal use. The primary cause of sensor failure is overvoltage (inadvertent connection of line voltage, for example) or incorrect polarity on hookup. The sensor is replaced by removing the strain relief, then threading out the sensor retainer plug. Remove the entire sensor capsule by pulling on the cable. The new sensor capsule can then be installed, orientation is not critical. Replace the retainer plug, and then replace and tighten the strain relief.

Rotor Replacement

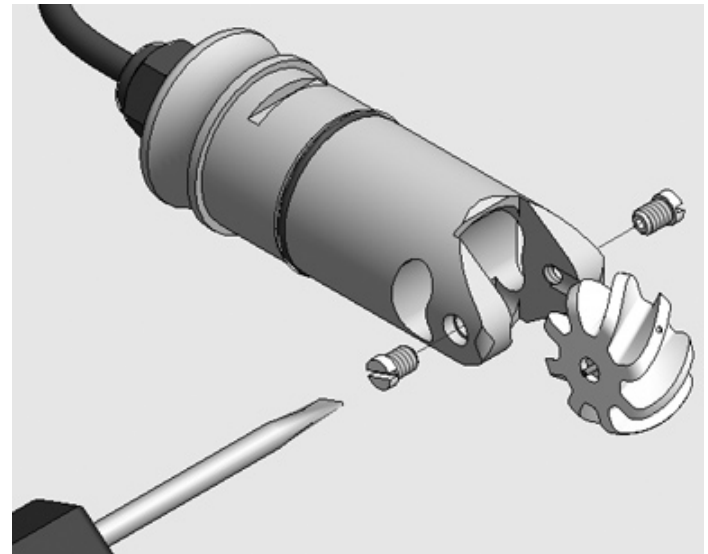

PARTS EXPLOSION

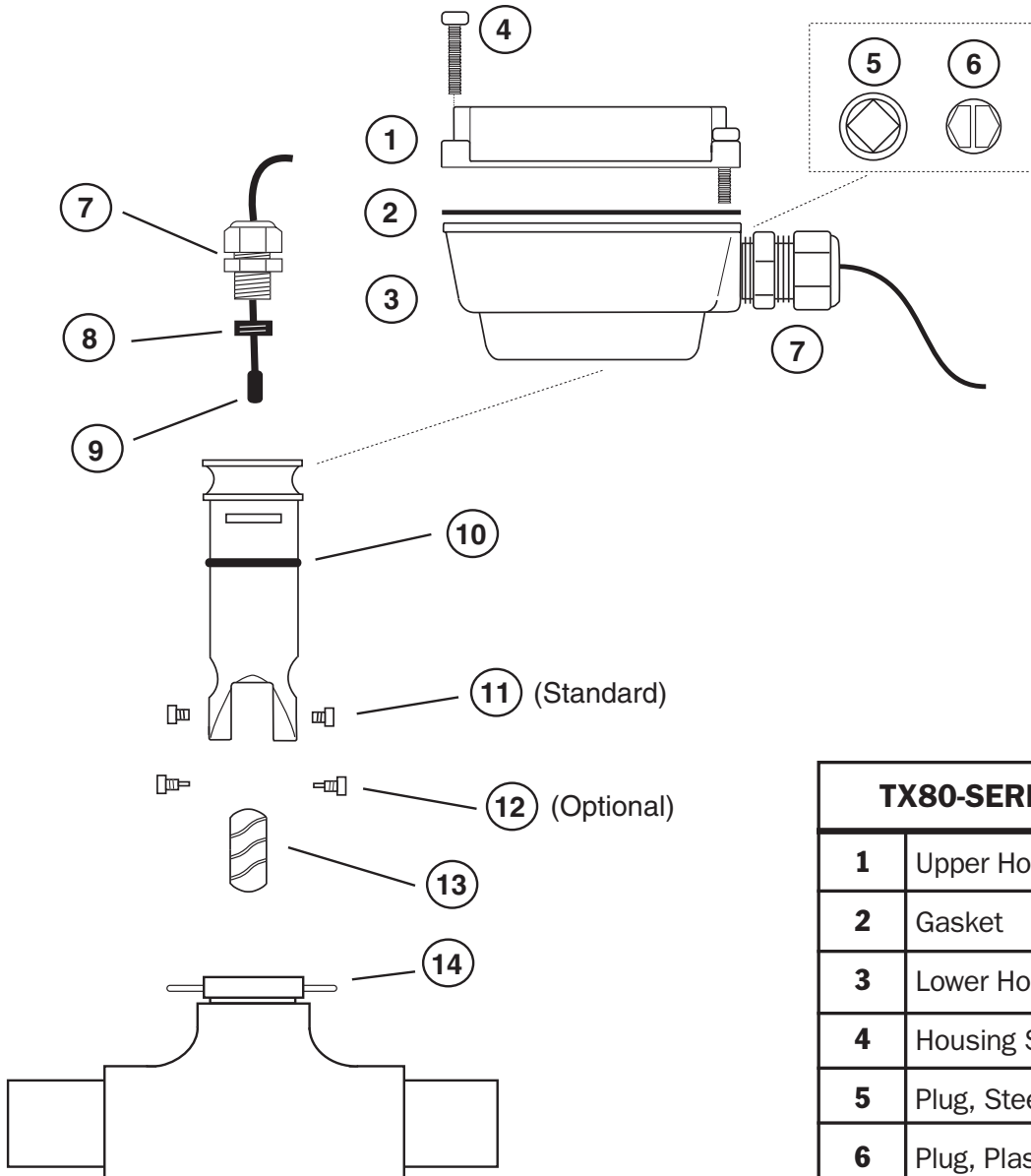

TX80-SERIES PARTS LISTING		
1	Upper Housing	26181
2	Gasket	26211
3	Lower Housing	29930
4	Housing Screw	26229
5	Plug, Steel	26073
6	Plug, Plastic	26079
7	Strain Relief	07655
8	Sensor Retaining Screw	25321
9	Pick Up, Standard Low Power or Pick Up, Micro Power (FT415/DL76)	26310 29953
10	O-Ring, EPDM or O-Ring, Viton	25081 16455
11/13	Rotor Repair Kit (Polypro/Tungsten Carbide)	25930
12/13	Rotor Repair Kit (Kynar/Ceramic)	25945
14	U-Clip	15527

TROUBLESHOOTING

Problem	Probable Cause	Try...
No signal after installation	Insufficient flow Bad connections to control electronics Incompatible control Damaged or missing rotor Failed magnetic sensor	Reduce pipe size if possible, use different type of sensor Reconnect if necessary Use different power supply Add pull up resistor, (See pg. 5) Obtain new rotor and replace (See pg. 7) Replace magnetic sensor
Inaccurate metering	Not enough straight pipe between meter and severe flow disturbance Wrong K-Factor entered Magnetic sensor failing to pick up each blade	Move meter away from flow disturbance or field calibrate



Seametrics Incorporated • 19026 72nd Avenue South • Kent, Washington 98032 • USA
(P) 253.872.0284 • (F) 253.872.0285 • 1.800.975.8153 • www.seametrics.com

LT-65200048-C
6/25/10